

INSTALLATION GUIDE  
QUICKIE Q500 M



# INSTALLATION GUIDE

## QUICKIE Q500 M

### PACKAGE CONTENTS

- A. Rear SmartFrame™ (1)
- B. Left SmartFrame™ (1)
- C. Right SmartFrame™ (1)
- D. Scout (1)
- E. Footplate Drill Guides (2)
- F. Dashboard (1)
- G. Dashboard Reference Card (2)
- \*Bracket based on order form:*
  - H. LED Joystick Dashboard Bracket (1)
  - I. Color Joystick Dashboard Bracket (1)
  - J. Color Joystick Spacer (1)
  - K. CJSM 1/2 Dashboard Bracket (1)
  - L. OMNI Dashboard Bracket (1)
- M. LuciLink™ Hub & Wheelchair Key™ (1)
- N. Alcohol Wipe (2)
- O. Battery Service Tag (1)
- P. 1/4" Drill Bit (1)
- Q. 5/16" Drill Bit (1)
- R. M6 x 30mm Socket Head Bolt (4)
- S. M8 x 16mm Low Profile Socket Cap Screw (4)
- T. M5 x 16mm Hex Head Screw (2)
- U. M5 x 14mm Phillips Head Screw (1)
- V. M5 x 8mm Hex Head Screw (2)
- W. M5 x 8mm Phillips Head Screw (3)
- X. 4-40 x 3/16 Phillips Head Screw (4)
- Y. M5 Nylon Insert Locknut (1)
- Z. #10 Washer (2)
- AA. Rubber Backed Washer (2)
- AB Cable Clips
- AC. Zip Ties
- AD. User Manual

### You will also need:

- 3mm Allen Wrench
- 5mm Allen Wrench
- 8mm Socket Wrench
- Phillips P1 Screwdriver
- Masking Tape
- Drill
- Zip Tie Cutter

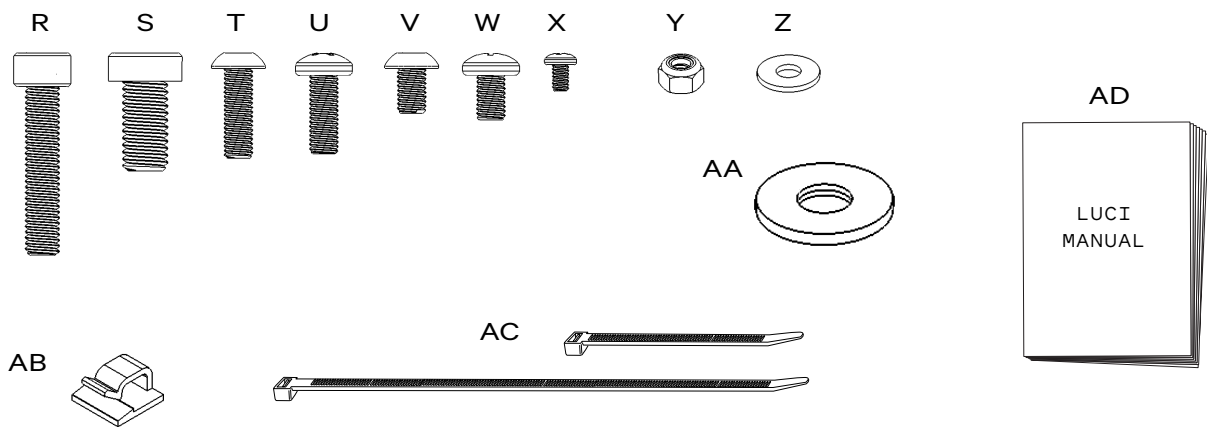
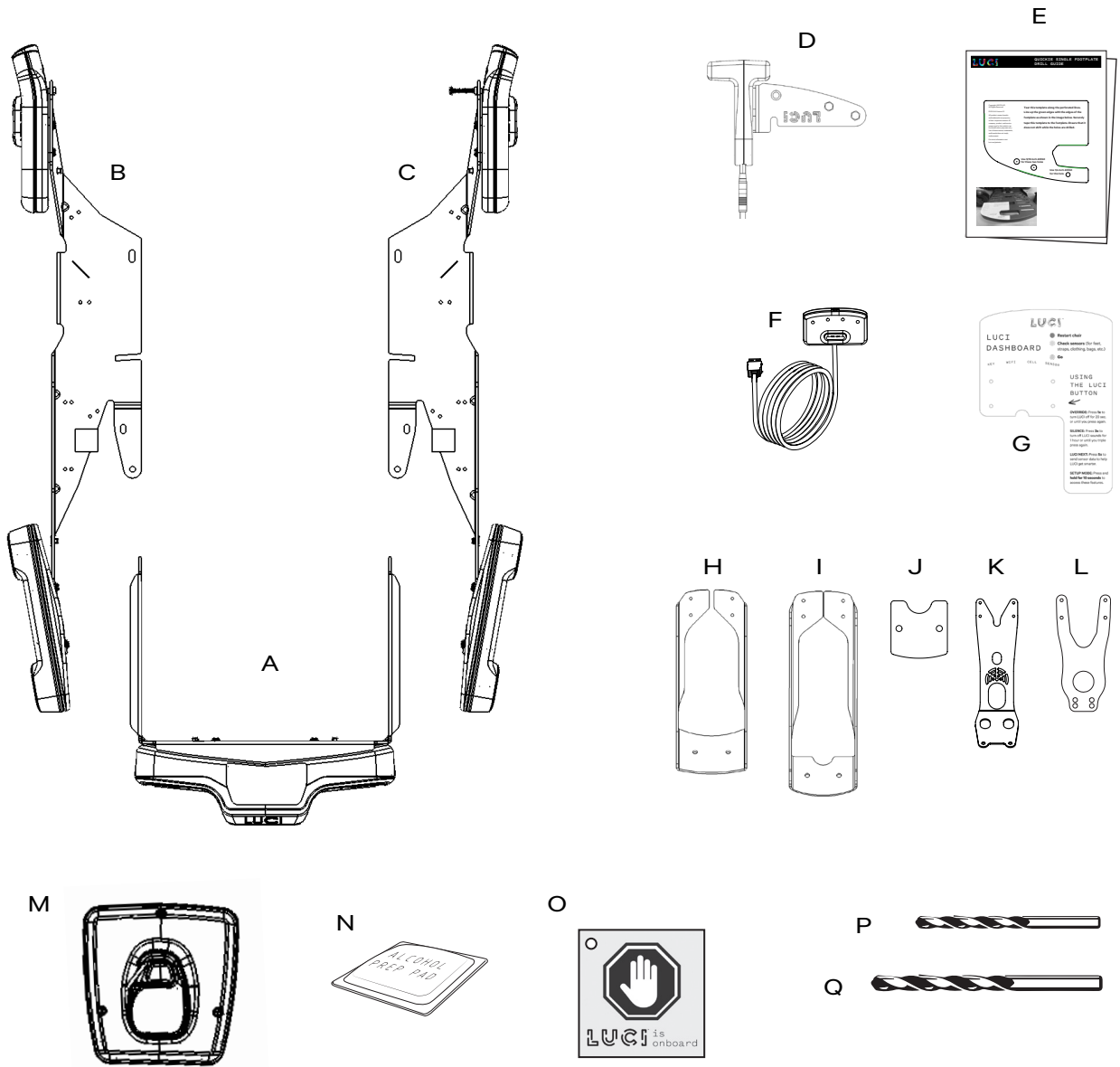



# INSTRUCTIONS

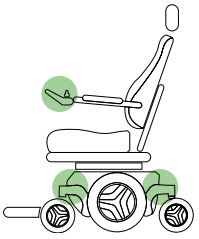

## STEP 1 - PREPARE WHEELCHAIR BASE

### Tools Required

- 5mm Allen Wrench

Use a 5 mm Allen wrench to loosen the two bolts in the back cover (Figure 1A) and remove the back cover. If the wheelchair has a seat elevator, turn the wheelchair on and raise the seat completely to allow adequate room to work comfortably (Figure 1B), then turn the wheelchair off. Otherwise, remove the two thumbscrews under the front of the seating assembly and flip the seating assembly back to open the battery compartment and gain adequate access (Figure 1C).

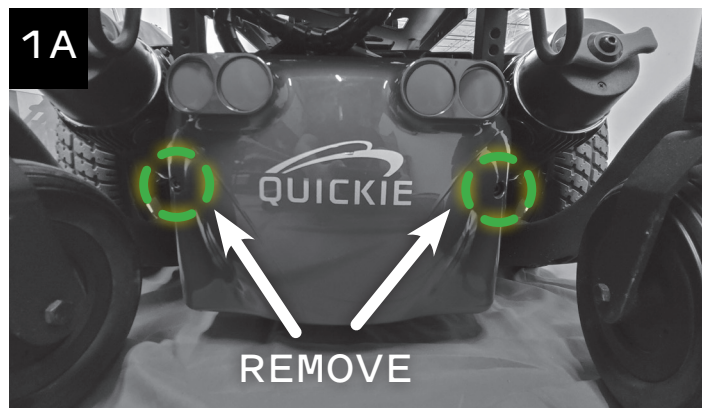

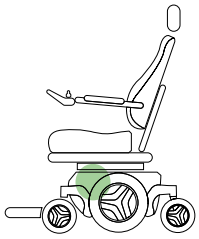

## STEP 2 - SECURE SIDE SMARTFRAMES

### Tools Required

- Rear SmartFrame™ (A)
- Left SmartFrame™ (B)
- Right SmartFrame™ (C)
- M6 × 30mm Bolts (R)
- 5mm Allen Wrench

Using a 5mm Allen wrench, remove the bolts on the front and both sides of the front cover (Figure 2A) and remove the front cover completely. Place the three parts of the SmartFrame (A, B and C) on the floor around the wheelchair. Set the Left SmartFrame (B) on the left side of the chair where the front cover was removed, lining up the bolt holes (Figure 2B). Do not insert the bolts yet.

**i** Note: There is a bolt that is located in between the tire and the tie-down hook on the side of the wheelchair. This bolt will insert into the hole near the front of the bracket on the 90 degree bend, holding the bracket in place.

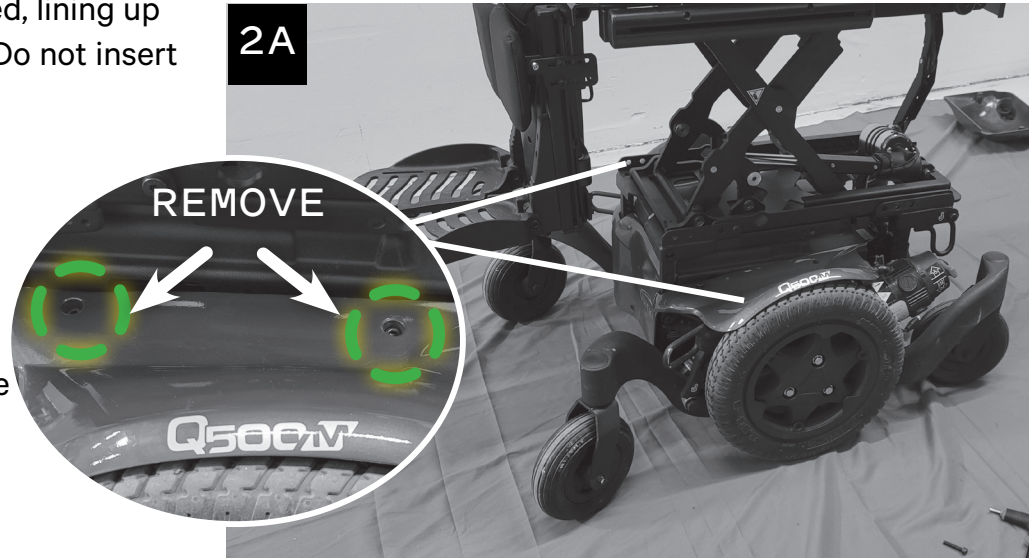

Repeat the process on the right side of the wheelchair: set the Right SmartFrame (C) on the right side of the wheelchair, slotting it onto the bolt between the tire and the tie down. Replace the front cover onto the chair. Loosely insert four M6 x 30mm bolts (R), two on each side, securing the Left and Right SmartFrames between the wheelchair and front cover (Figure 2C). Reinsert the two original screws in the front of the front cover and tighten all bolts and screws.

If the battery compartment was opened, flip the seating assembly back into place and reinsert the thumbscrews that hold the seating assembly in place.

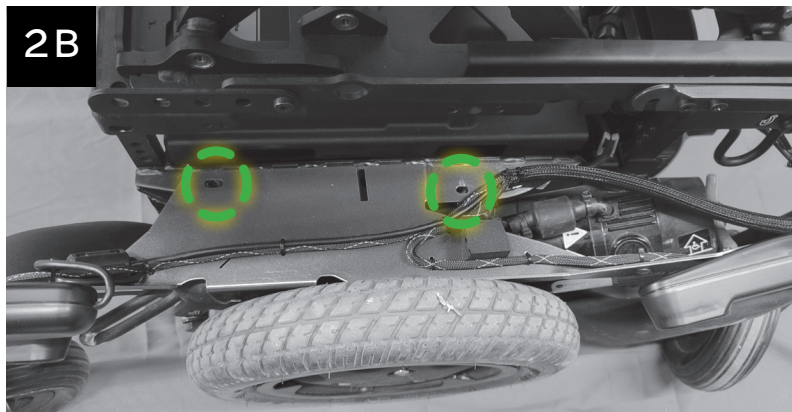

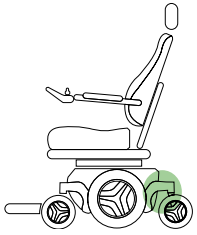

### STEP 3 - CONNECT LUCI TO THE WHEELCHAIR

#### Tools Required

- Rear SmartFrame™ (A)
- Battery Service Tag (O)
- Zip Tie (AC)

Attach the Battery Service Tag (O) to the thumbscrew cable lanyard with a Zip Tie (AC) (Figure 3A).

Remove one reflector from the rear cover by rotating the tabs on the inside and pushing the reflector out (Figure 3B). Route the two R-NET cables from the Rear SmartFrame (A) through the opening in the rear cover (Figure 3C). On the back of the wheelchair, unplug the main R-NET cable on the far left (Figure 3D) and plug it into the female R-NET cable end on LUCI. Plug the male R-NET cable end from LUCI into the main wheelchair R-NET outlet on the far left (Figure 3E). Turn the wheelchair on to ensure all power cables have been properly connected. Turn off the wheelchair.

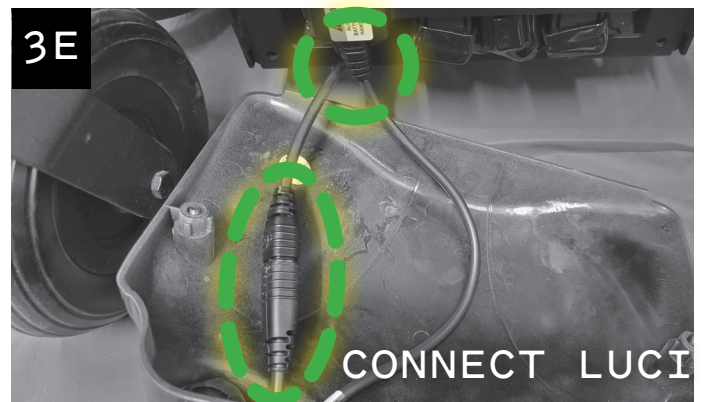
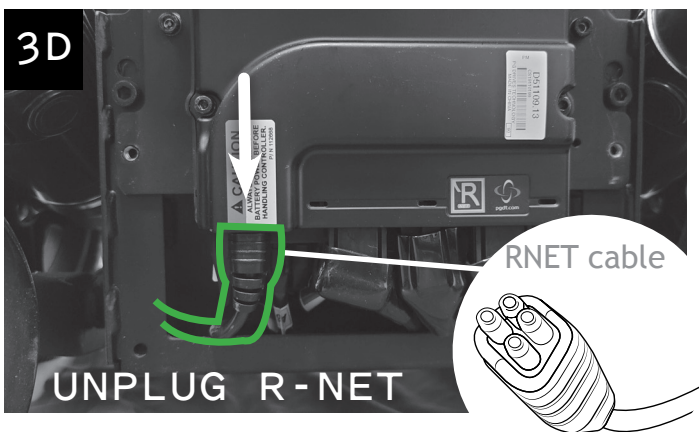
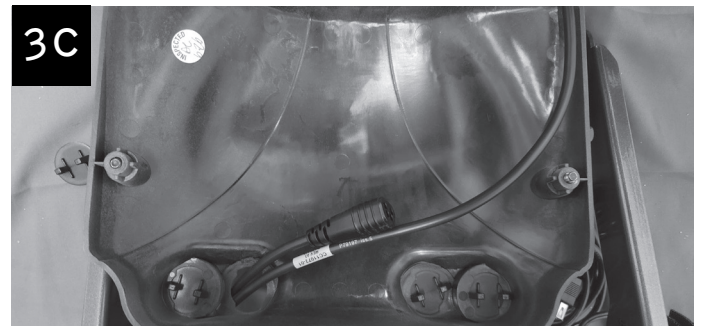
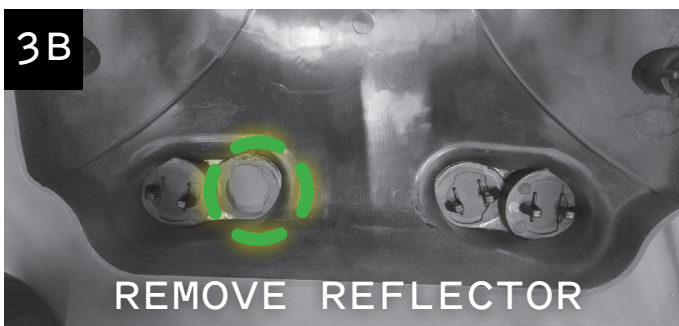



## STEP 4 - SECURE THE REAR SMARTFRAME

### Tools Required

- Rear SmartFrame (A)
- M8 x 16mm Screws (S)
- 5mm Allen Wrench

Use the 5mm Allen wrench to reattach the rear cover on the wheelchair, using the original bolts (Figure 4A). On both sides of the wheelchair, remove the forward-most bolt completely and then loosen the rear bolt. Install the Rear SmartFrame (A) by slotting it onto the rear bolts. Insert M8 x 16mm Screws (S) into the front holes and tighten enough to keep the SmartFrame from moving. Replace the rear bolts with M8 x 16mm Screws (S) on both sides (Figure 4B).

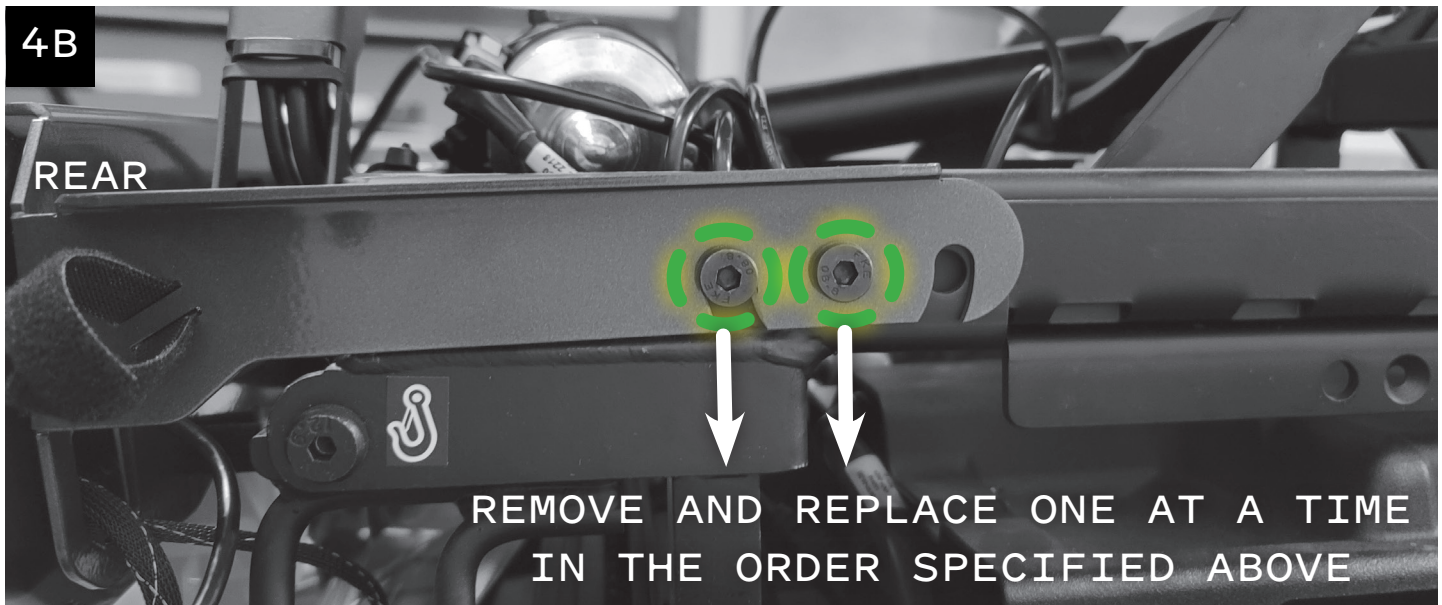

Make sure the bubble is between the lines on the level taped to the SmartFrame and tighten all four screws (Figure 4C).

**i** Note: The manufacturer recommends 13.6 - 14.9 N-m (120 - 130 in-lb) of torque on these fasteners. Remove the bubble level once the SmartFrame is level and secure.



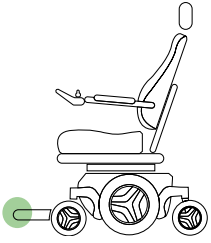

## STEP 5 - ATTACH SCOUT

### Tools Required

- Scout (D)
- Footplate Drill Guides (E)

Find the instructions for the appropriate footplate type below - single, standard dual, or large dual. For single or standard dual footplates, choose the correct Drill Guide (E) and tear it out along the perforated lines.

### SINGLE FOOTPLATE

#### Tools Required

- Masking Tape
- Drill
- Phillips P1 Screwdriver
- 1/4" Drill Bit (P)
- 5/16" Drill Bit (Q)
- M5 x 14mm Screw (U)
- M5 x 8mm Screws (W)
- M5 Nylon Locknut (Y)
- #10 Washers (Z)
- 8mm Socket Wrench

Line up the Single Footplate Drill Guide and tape it to the footplate (Figure 5A). Drill the two larger holes with the 5/16" drill bit (Q) and the smaller hole with the 1/4" drill bit (P) as marked on the template (Figure 5B). Place the Scout (D) on top of the footplate, aligning the screw holes in the bracket with the drilled holes in the footplate. Place #10 Washers (Z) on two of the M5 x 8mm Phillips Head Screws (W), raise the footplate and loosely insert the screws into the 5/16" holes from the bottom of the footplate (Figure 5C) to hold the Scout bracket in place. Insert the M5 x 14mm Phillips Head Screw (U) into the 1/4" hole from the top of the footplate (Figure 5D). Use an 8mm socket wrench to secure it from the bottom with the M5 Nylon Locknut (Y). Tighten all three screws.

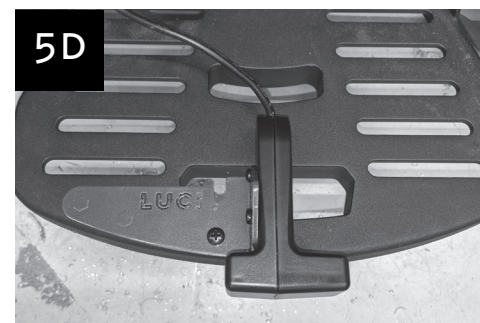
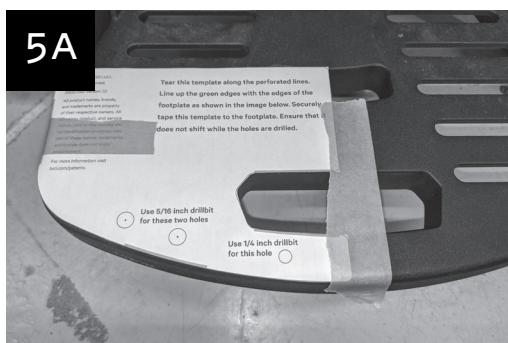

## STANDARD DUAL FOOTPLATE

### Tools Required

- Masking Tape
- Drill
- Phillips P1 Screwdriver
- 5/16" Drill Bit (Q)
- M5 x 8mm Screws (W)
- #10 Washers (Z)

Line up the Dual Footplate Drill Guide and tape it to the right footplate (Figure 5E). Note which slot on the template to line up with the footplate, depending on the footplate style. Loosely insert one M5 x 8mm Phillips Head Screw (W) through the template and into the threaded hole to help keep the template in place. Drill the two holes with the 5/16" drill bit (Q) as marked on the template (Figure 5F). Remove the M5 x 8mm screw (W) and discard the template. Place the Scout (D) on top of the footplate, aligning the screw holes in the bracket with the drilled holes in the footplate. Loosely reinsert the M5 x 8mm Screw (W) into the threaded hole (Figure 5G). Raise the footplate, place #10 Washers (Z) on the remaining two M5 x 8mm Phillips Head Screws (W) and insert them into the 5/16" holes from the bottom of the footplate (Figure 5H). Tighten all three screws.

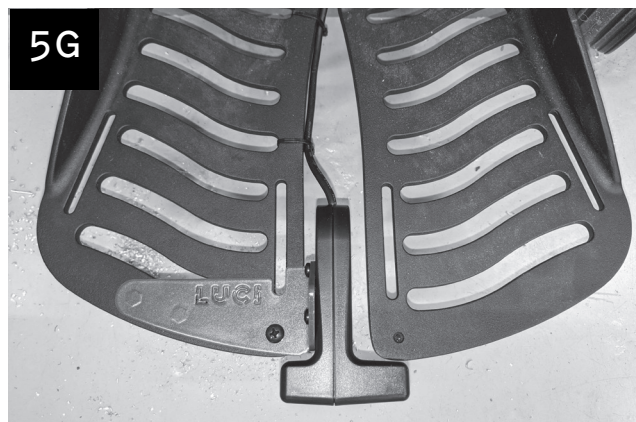
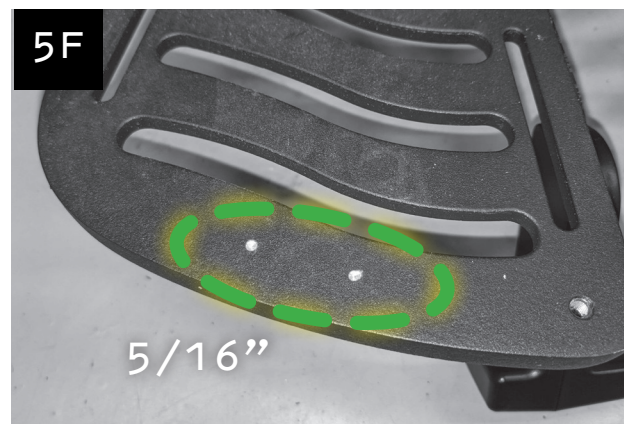
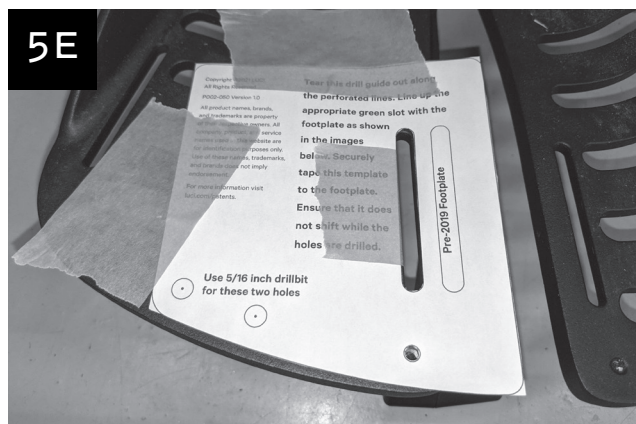

## LARGE DUAL FOOTPLATE

### Tools Required

- Phillips P1 Screwdriver
- Rubber Backed Washers (AA)
- M5 x 8mm Screws (W)

Place the Scout (D) on top of the right footplate and loosely insert one M5 x 8mm Phillips Head Screw (W) into the threaded hole (Figure 5I). Raise the footplate and line up the holes in the bracket with the slot in the footplate so that the stud is pressed against the top of the slot (Figure 5J). Place Rubber Backed Washers (AA) on the remaining two M5 x 8mm Phillips Head Screws (W) and insert them into the holes from the bottom of the footplate (Figure 5K). Make sure the rubber side is against the footplate and tighten both screws. Note that the washers are slightly domed and will flatten out when they are sufficiently tightened. Lower the footplate and tighten the top screw.

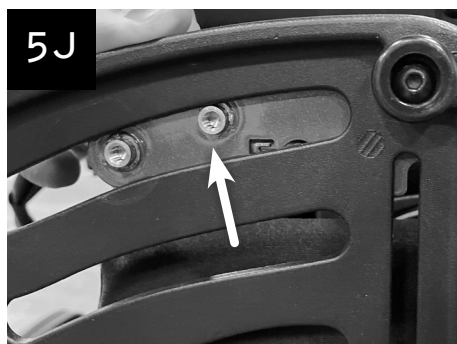
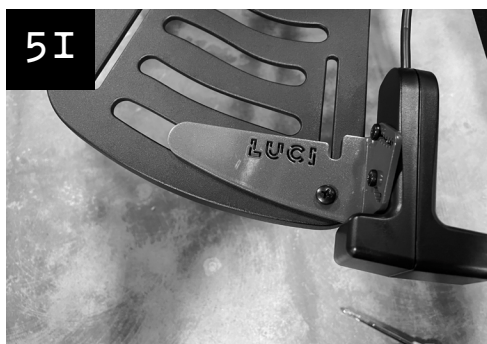

**▲ Caution:** Regardless of the type of footplates, the Scout should be level for optimal performance (Figure 5L1). In some cases, the footrest and Scout angle downward when the user is seated (Figure 5L2). To ensure that the Scout does not see the ground as an obstacle, angle the footrest and/or Scout slightly upward (Figure 5M1) so that the Scout is level when the user is seated (Figure 5M2).

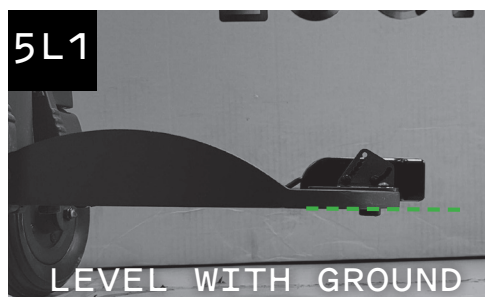

**i Note:** If the driver typically drives with the footplate raised, the Scout should be adjusted, following the instructions in Step 5B.

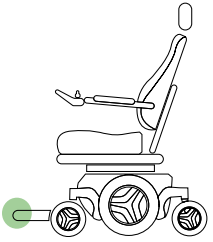

## STEP 5B - ADJUSTABLE SCOUT OPTIONS

### Tools Required

- Phillips P1 Screwdriver

The Scout works best when it is level with the ground or facing slightly upward. For the majority of drivers the default Scout position will work well and this step can be skipped (Figure 5B1). However, if the driver primarily drives with the footplate significantly raised or lowered, the Scout should be adjusted to an orientation that is level with the ground, to ensure proper functioning and obstacle detection.

The adjustable footplate bracket allows for variability in Scout orientation (Figure 5B2). If the driver typically drives with the footplate up, the Scout can be mounted at up to 30 degrees tilt (Figure 5B3).

**⚠ Caution:** Do not mount the Scout facing downward, as this will cause it to see the ground as an obstacle and inhibit forward motion (Figure 5B4).

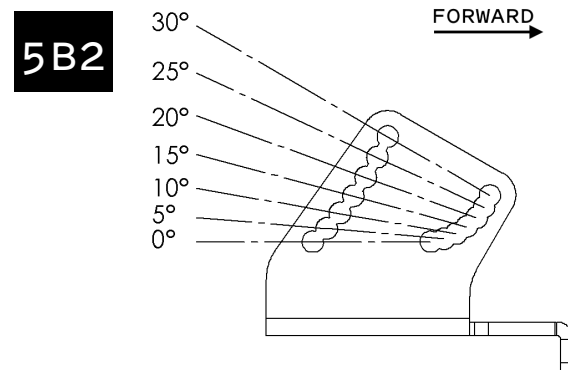

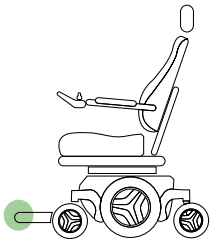

## STEP 6 - ROUTE SCOUT CABLE

### Tools Required

- Alcohol Wipe (N)
- Cable Clips (AB)
- Zip Ties (AC)

Route the Scout cable along the side and top of the footplate (Figure 6A), using zip ties (AC) and cable clips (AB) along the way as needed. Before applying cable clips, be sure to thoroughly clean the plastic with an alcohol wipe (N). Raise the leg rest to its fullest extent and continue routing the cable along the side of the leg rest, routing toward the back of the wheelchair. Follow existing cabling and cable clips where possible (Figure 6B).

**⚠ Caution:** Do not route the cable under the leg rest post.

**ℹ Note:** Use an alcohol wipe to thoroughly clean the plastic before applying cable clips. Cable clips need firm pressure to properly adhere, and may come off in the first few minutes if moved too aggressively when putting cables into them.

**⚠ Caution:** Ensure there is enough slack in the USB cable so that the seat and leg rest can move to their full extent, without causing tension on the cable.

**⚠ Caution:** All cables should be installed, bundled and routed so as to avoid damage to the cables through pinching, dragging, etc. and to avoid excess cable length that could lead to entanglement or strangulation.

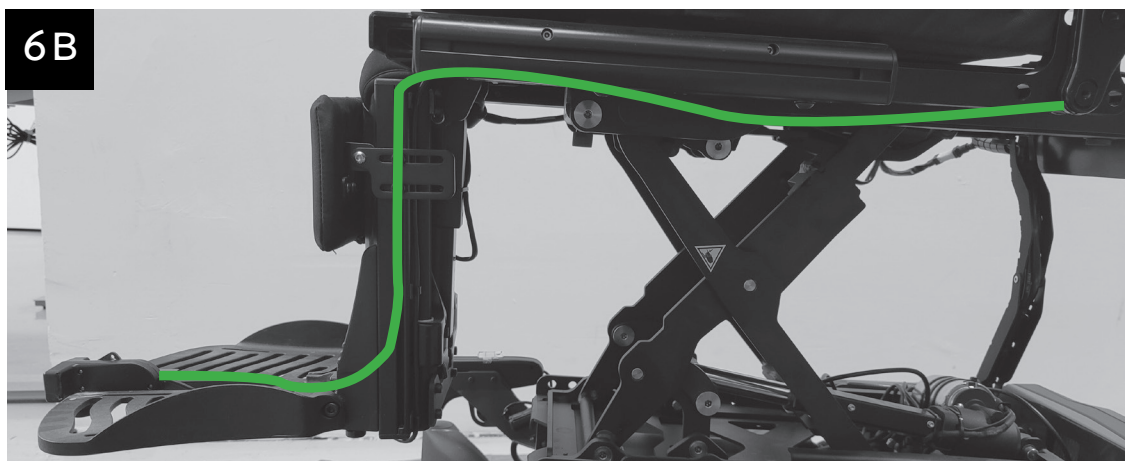
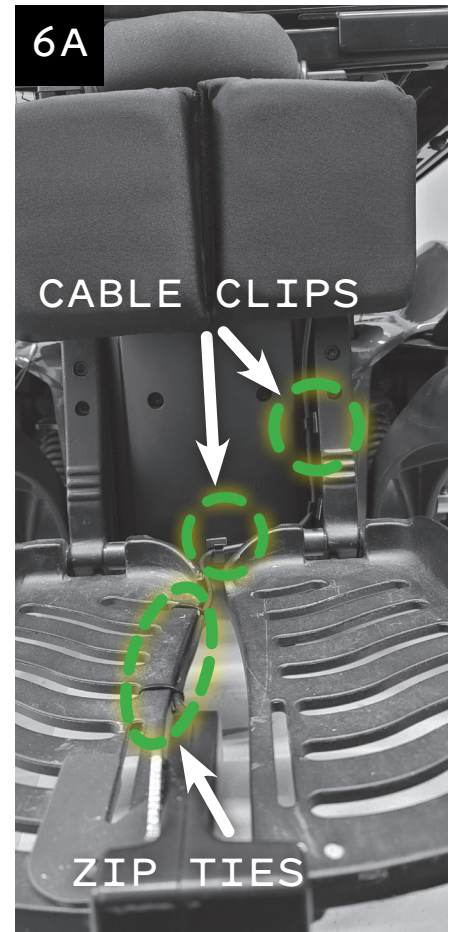

# STEP 7 - INSTALL THE DASHBOARD

**i** Note: To install the Dashboard, you will need to select the correct Dashboard Bracket depending on the wheelchair's drive system:

- LED Joystick                      - LED Joystick Dashboard Bracket (H)   - Step 7A
- Color Joystick                 - Color Joystick Dashboard Bracket (I)   - Step 7B
- Standard Joystick             - CJSM 1/2 Dashboard Bracket (K)       - Step 7C
- Omni Alternative Drive       - Omni Dashboard Bracket (L)            - Step 7D

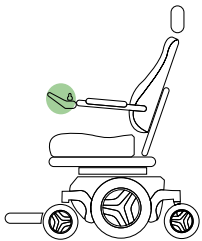

## STEP 7A - LED JOYSTICK

### Tools Required

- Dashboard (F)
- LED Joystick Dashboard Bracket (H)
- Dashboard Reference Card (G)
- 3mm Allen Wrench
- 5mm Allen Wrench
- Phillips P1 Screwdriver
- M5×16mm Hex Screws (T)
- 4-40 × 3/16 Phillips Screws (X)

Remove the joystick module from the armrest of the wheelchair by loosening the M6 screw using a 5mm Allen wrench (Figure 7A1). Caution: Do not lose the shim between the set screw and the post (Figure 7A1). Remove the two screws on the bottom of the joystick on either side of the adjustment rod, using a 3mm Allen wrench (Figure 7A2). Choose the correct (left or right) Dashboard Reference Card (G). Use four 4-40 x 3/16 inch screws (X) to attach the LED Joystick Dashboard Bracket (H) to the back of the Dashboard (F), with the Dashboard Reference Card

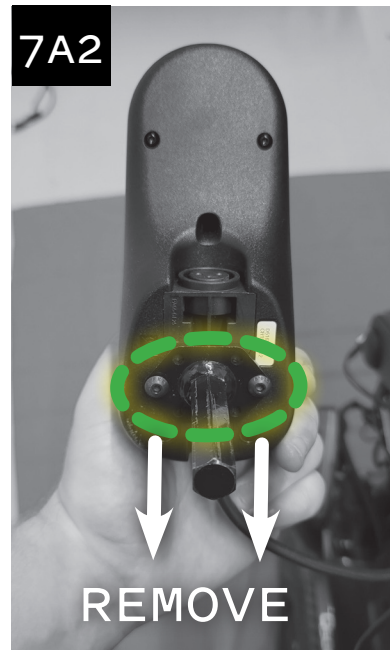
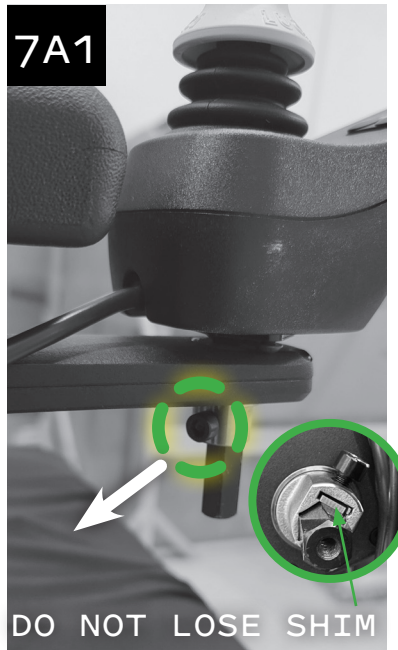

(G) behind the bracket (Figure 7A3). Route the Dashboard cable along the lower inside bend of bracket and place the joystick module inside the Bracket. Insert two M5 x 16mm Hex Head Screws (T), tightening them with a 3mm Allen wrench (Figure 7A4). Reattach the entire joystick module to the wheelchair, reinsert the shim, and tighten the original M6 screw (Figure 7A5).

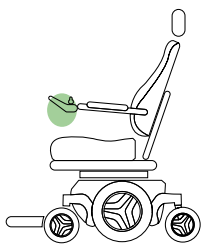
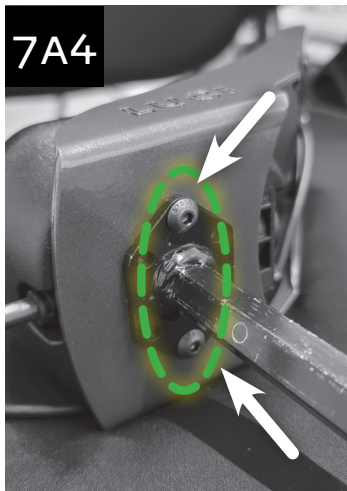

## STEP 7B - COLOR JOYSTICK

### Tools Required

- Dashboard (F)
- Color Joystick
- Dashboard Bracket (I)
- Color Joystick Spacer (J)
- Dashboard Reference Card (G)
- 3mm Allen Wrench
- 5mm Allen Wrench
- Phillips P1 Screwdriver
- M5x16mm Hex Screws (T)
- 4-40 x 3/16 Phillips Screws (X)

Remove the joystick module from the armrest of the wheelchair by loosening the M6 screw using a 5mm Allen wrench (Figure 7B1). Caution: Do not lose the shim between the set screw and the post (Figure 7B1). Remove the two screws on the bottom of the joystick on either side of the adjustment

rod, using a 3mm Allen wrench (Figure 7B2). Feed the joystick cable through the split in the Color Joystick Bracket (I) (Figure 7B3). Choose the correct (left or right) Dashboard Reference Card (G). Use four 4-40 x 3/16 inch screws (X) to attach the Color Joystick Dashboard Bracket (I) to the back of the Dashboard (F), with the Dashboard Reference Card (G) behind the bracket (Figure 7B4). Route the Dashboard cable along the lower inside bend of bracket and place the joystick module inside the bracket. Turn the joystick module upside down, and slide the Color Joystick Spacer (J) in between the joystick module and the bracket (Figure 7B5). Insert two M5 x 16mm hex head screws (T), tightening them with a 3mm Allen wrench (Figure 7B6). Reattach the entire joystick module to the wheelchair, reinsert the shim, and tighten the original M6 screw (Figure 7B7).

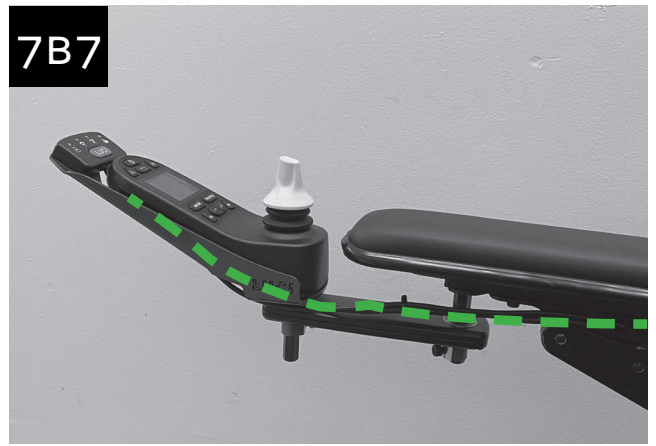
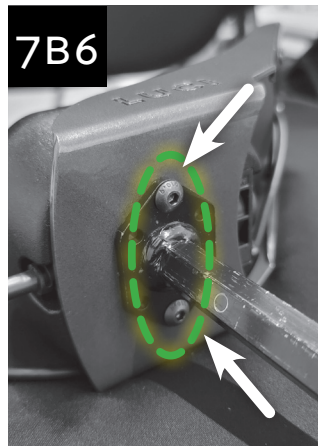
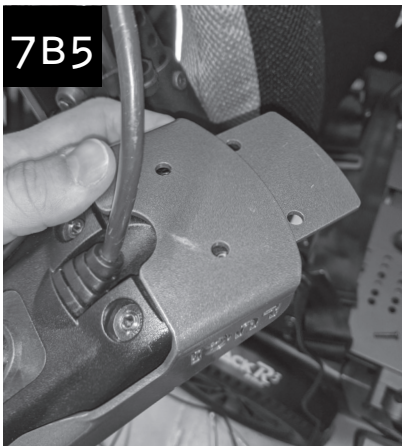
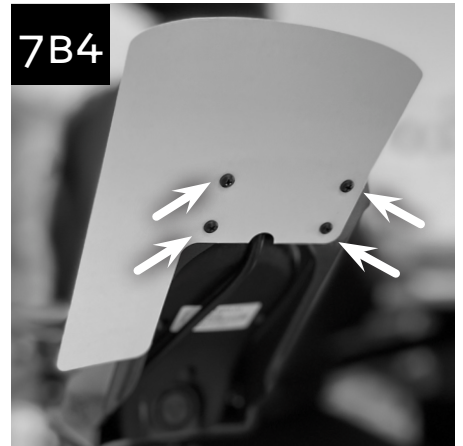
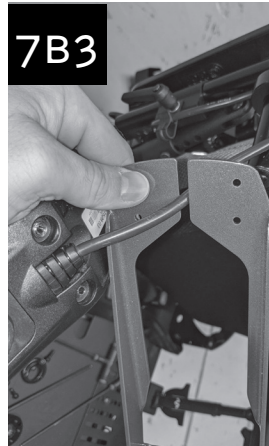
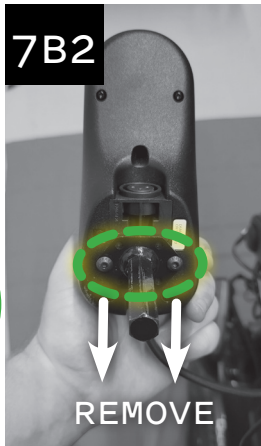



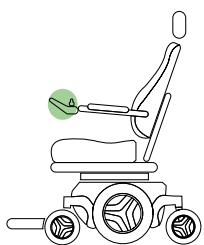

## STEP 7C - CJSM 1/2 JOYSTICK

### Tools Required

- Dashboard (F)
- CJSM 1/2 Joystick
- Dashboard Bracket (K)
- Dashboard Reference Card (G)
- 3mm Allen Wrench
- 5mm Allen Wrench
- Phillips P1 Screwdriver
- 4-40 x 3/16 Phillips Screws (X)
- Zip Tie (AC)

Choose the correct (left or right) Dashboard Reference Card (G). Use four 4-40 x 3/16 inch screws (X) to attach the bracket to the back of the Dashboard (F), sandwiching the Dashboard Reference Card (G) between them and ensuring the cable is routed correctly (Figure 7C1 or 7C2). Note that for newer wheelchairs, the joystick module is taller, so the Dashboard should only be attached to the top two holes on the bracket; insert screws into the top two holes on the Dashboard to ensure the unit stays sealed (Figure 7C2). Remove the joystick module from the armrest of the wheelchair by loosening the M6 screw using a 5mm Allen wrench. Use a 3mm Allen wrench to remove the metal bracket from the joystick module. Insert the Dashboard bracket between the armrest and the joystick module and reinsert the screws (Figure 7C3). Route and zip tie (AC) the cable as shown (Figure 7C3). Reattach the joystick module and tighten the original M6 screw.



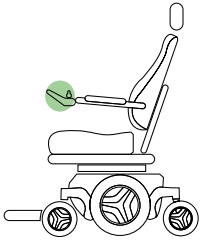

## STEP 7D - OMNI ALTERNATIVE DRIVE

### Tools Required

- Dashboard (F)
- Omni Dashboard Bracket (L)
- Dashboard Reference Card (G)
- 3mm Allen Wrench
- Phillips P1 Screwdriver
- M5 x 8mm Hex Screw (V)
- 4-40 x 3/16 Phillips Screws (X)

Choose the correct (left or right) Dashboard Reference Card (G). Use four 4-40 x 3/16 inch screws (X) to attach the bracket to the back of the Dashboard (F), sandwiching the Dashboard Reference Card (G) between them and ensuring the cable is routed correctly (Figure 7D1). Use a 3mm Allen wrench to remove the Omni module. Insert the Dashboard bracket between the armrest and the Omni module and attach using two M5 x 8mm hex head screws (V) (Figure 7D2).



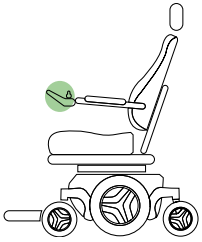

## STEP 8 - ROUTE THE DASHBOARD CABLE

### Tools Required

- Zip Ties (AC)

Regardless of the type of Dashboard Bracket that was used, route the Dashboard cable toward the back of the wheelchair, following existing cabling and using zip ties (AC) as needed (Figure 8A).

**i** Note: For alternative drive wheelchairs, the Dashboard (F) includes an auxiliary jack. Any momentary switch plugged into the jack can be used as the override button. If not used, be sure to keep the dust plug in the jack.

**⚠** Caution: All cables should be installed, bundled and routed so as to avoid damage to the cables through pinching, dragging, etc. and to avoid excess cable length that could lead to entanglement or strangulation.

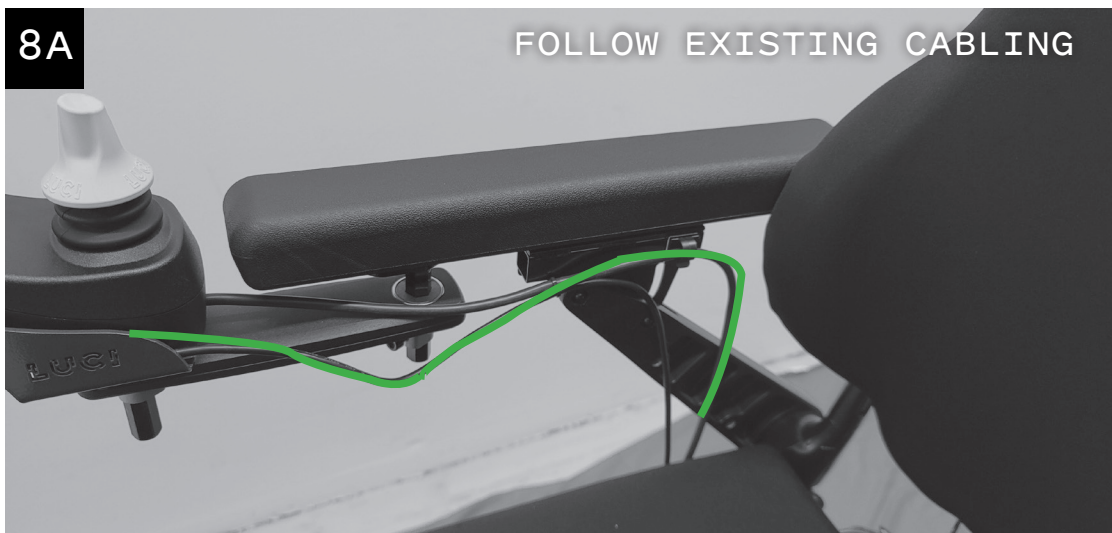

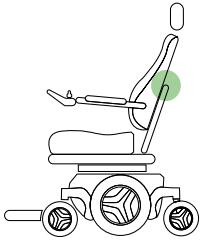

## STEP 9 - ATTACH LUCILINK HUB

### Tools Required

- Alcohol Wipe (N)
- Zip Ties (AC)
- LuciLink Hub (M)
- Phillips P1 Screwdriver

Use an alcohol wipe (N) to clean a flat area on the wheelchair seat back. Remove the Velcro backing from the LuciLink Hub (M) back cover and affix it to the cleaned area, so that the key is oriented as shown and the cable opening is at the bottom (Figure 9A). Clip existing zip ties along the drag chain one at a time and route the Rear SmartFrame USB cable along existing cabling and through the drag chain, zip tying it in place (Figure 9B). Use long zip ties (AC) to secure cables in the drag chain.

**i** Note: The LuciLink Hub may be placed anywhere on the seat back, as long as it does not limit the range of motion of the seat, armrests, etc.

**i** Note: Leave about 4-6 inches of slack in the USB cable before inserting it into the drag chain, so that SmartFrame can be rotated out of the way to allow for battery changes.

Use a Phillips P1 screwdriver to open the LuciLink Hub (M). Plug the Scout and Dashboard USB cables into the LuciLink Hub and connect the SmartFrame USB cable to the LuciLink Hub. Place the cables so that the LuciLink Hub can be closed (Figure 9C). Close the LuciLink Hub, reinsert and tighten the three screws (Figure 9D).

**i** Note: It may be easier to place the cables and close the LuciLink Hub by removing the back from the Velcro and holding the LuciLink Hub horizontally.

**▲** Caution: All cables should be installed, bundled and routed so as to avoid damage to the cables through pinching, dragging, etc. and to avoid excess cable length that could lead to entanglement or strangulation.

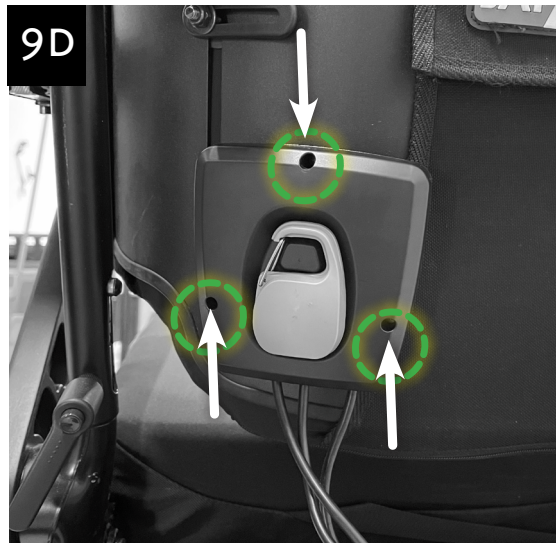

## ONCE LUCI IS INSTALLED:

- Power on the wheelchair and ensure that the seat, armrests, and footrest are able to move to their full extent without pinching or pulling any cables, or compressing any parts of LUCI.
- Ensure that leg pads and accessories, such as lateral thigh supports, do not contact or block the front camera pods and/or headlights at the lowest seat elevation.
- Confirm the Dashboard Reference Card is attached to the LUCI Dashboard.
- Check that there are no loose, pinched or dragging cables.
- Confirm the Sensor Status light on the Dashboard is orange (demo mode).
- Press the LUCI button and make sure the LUCI button lights up blue, the chair can move in each direction when clear, and the chair stops in a blocked direction of travel.

Before releasing the wheelchair to the user, the system will need to be configured. With the user in the wheelchair, follow the instructions in the LUCI Quick Setup Guide.

CONGRATULATIONS,  
you have installed

**LUCI**®

Copyright © 2023 LUCI, All Rights Reserved.

All product names, brands, and trademarks are property of their respective owners. All company, product, and service names used are for identification purposes only. Use of these names, trademarks, and brands does not imply endorsement.

For more information on our patents, please visit [luci.com/patents](https://luci.com/patents)

## REPLACING WHEELCHAIR BATTERIES WITH LUCI INSTALLED

If you need to replace the batteries on a Quickie Q500 M that has LUCI installed, follow these steps:

1. Using a 5mm Allen wrench, loosen all four bolts on the Rear SmartFrame (two on each side). Rotate the Rear SmartFrame up and tighten the front bolts just enough that the Rear SmartFrame is held in place.

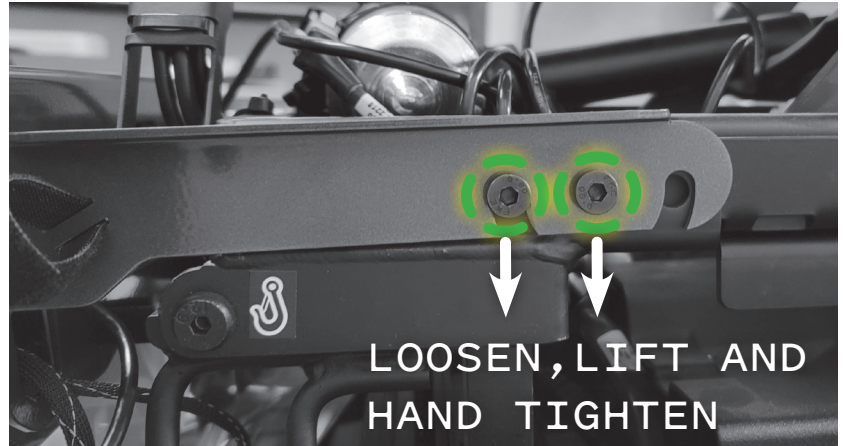

2. Remove the two thumbscrews that keep the seating assembly down. Flip the seating assembly back and swap the batteries as you normally would.

**⚠ Caution:** Make sure the Rear SmartFrame is rotated out of the way as you flip the seat open, to avoid damaging the SmartFrame.



3. Close the seating assembly and reinsert the thumbscrews. Loosen the Rear SmartFrame bolts, adjust the SmartFrame so the top edge of the bracket is level with the ground, and tighten all four bolts. The manufacturer recommends 13.6 - 14.9 N-m (120 - 130 in-lb) of torque on these fasteners. Ensure all cables are neatly routed to avoid pinching or dragging.



LUCI®

LUCI.COM

613-00015 Rev B