



WHEELCHAIR BETTER SAFER SMARTER

USER GUIDE

W E L C O M E

THANK YOU FOR CHOOSING LUCI[®], AND WELCOME
TO OUR COMMUNITY - WE'RE HERE FOR YOU!

We created LUCI to make this beautiful, dangerous world more accessible for my daughter, Katherine. And we know every LUCI user is as precious to someone as Katherine is to us. That's why our Customer Experience Team wants to make sure you have all the answers you need. And why we worked to make this guide as easy and helpful as possible.

Before using **LUCI** – please read and understand the instructions in this guide.

If you have questions or concerns about these instructions, or general safety and operation of LUCI, you can:

Call us at
615-813-LUCI (5824)

Email us at
lucihelps@LUCI.com

Visit **LUCI.com**, which is
full of info and FAQ's.

Lastly, I hope you'll check out our various social media channels to stay up to date on all things LUCI. Thank you again. We're excited to help you #WheelchairSmarter.

All the best,

A handwritten signature in white ink, appearing to read 'B. Dean', with a stylized flourish at the end.

Barry Dean
CEO & Co-Founder

MODEL INFORMATION

This User Guide is for:
LUCI® Model Numbers 100 – 112

WARRANTY

Terms of Use and Warranty information are available at:
luci.com/legal

CONTACT

You may reach us at:

LUCI Mobility, Inc.
101 Creekside Crossing, Ste 1700, #244
Brentwood, TN 37027
info@luci.com
luci.com

CUSTOMER EXPERIENCE TEAM

615-813-LUCI
lucihelps@luci.com



TABLE OF CONTENTS

Who We Are	2	MyLUCI® Health Monitoring	19
LUCI Overview	3	Connecting To Wi-Fi	20
LUCI Hardware	5	Why and How	20
LuciLink® Hub and Wheelchair Key	6	Software Updates	20
Dashboard and LUCI Button	7	MyLUCI® Voice	20
LUCI Safety	8	Using Alexa with LUCI	21
Collision Avoidance: 360°	8	Using Google Assistant with LUCI	21
Collision Avoidance: Front & Back	9	Updating Your Drive Settings	22
Collision Avoidance: Side To Side	10	Basic Settings	22
Collision Avoidance: What Scout Sees	10	Advanced Settings	23
Drop-Off Protection	11	Care and Maintenance	24
Ground Confidence	11	Cleaning	24
Tip Protection	12	Service	24
LuciLink Remote Stop	12	Troubleshooting	25
Things To Keep In Mind	13	Get Home Safe Mode	25
LUCI Driver Assist	14	Common Problems	25
RampAssist	14	The LUCI Dashboard	25
Things to Keep in Mind	15	Warnings & Notifications	26
Driving With LUCI	16	Technical Specifications	30
MyLUCI®	18	Notes	35
Data Privacy	18		
Support Team	18		
LUCI View	18		

WHO WE ARE

LUCI started with a little girl in a power wheelchair, a mom who chose fight over flight, and two brothers who dared to take matters into their own hands.

Driven by impatience with a world where people in wheelchairs are asked to wait when it comes to innovative technology – we created LUCI to change that. A company founded to build to the need, not just the code. We sought out riders, therapists, ATPs and experts...we listened and got to work.

LUCI is made for people who don't believe in the word no. The girl with a wild streak and music in her blood. The mom who'd never let anything stifle her son's independent spirit. The grandfather who still hasn't seen enough of the world and is ready for another spin. The disabled vet who never lost the need for speed.

These people drive our hardware, our software, and our core philosophy.

LOVE TOUGH .

This is personal for us. We got tired of waiting for someone else to make life better for the people we love, so we've done the hard things required to bring innovation to everyone.

We value the subtle, but precious, focus that keeps the person at the center of our technology. Autonomy is not our goal – independence is.

HUMAN ENGINEERED .

Billing codes should never define what wheelchair riders need or have access to. So, we focus on the wishes and the needs, the what-ifs and the dreams, rather than codes.

BUILD TO THE NEED, NOT THE CODE .

We know we don't have all the answers, but we are seeking out and listening to riders, caregivers and other experts. We want to work with anyone who wants to innovate mobility.

FUELED BY COLLABORATION .

LUCI OVERVIEW

AWARD - WINNING SMART
WHEELCHAIR TECHNOLOGY
REIMAGINING MOBILITY™
AT EVERY TURN.

LUCI is the first and only smart technology accessory for power wheelchairs, designed to give riders a safer and more confident driving experience.

LUCI can prevent power wheelchair tips, collisions, and falls before they happen, thanks to a platform which helps the wheelchair “see” its environment and respond to steering input from the user. The result is safe, confident independence.



Enhanced
Mobility Platform



Collision
Avoidance

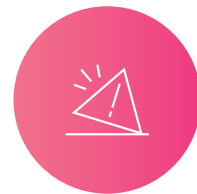

Drop-off and
Tip Protection

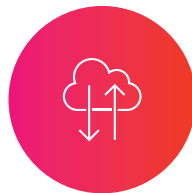

Cloud-based
Communication
and Alerts



Home Assistant
Compatibility

INTENDED USE



LUCI is an accessory for a power wheelchair. LUCI interfaces with the existing power wheelchair and uses existing bolts on the wheelchair base. LUCI is intended for use in home healthcare environments. LUCI consists of wheelchair mounted hardware (SmartFrame, Scout, Dashboard, and LuciLink® Hub), LuciLink® Wheelchair Key, and the MyLUCI® App. LUCI is intended to be installed on your power wheelchair by an authorized technician. After proper installation and setup, LUCI begins working as soon as you turn on your wheelchair. It connects to the wheelchair's power system and helps you maneuver in your environment safely. LUCI is suitable for continuous operation while you are using your wheelchair. LUCI is also able to send alerts to contacts and caregivers at your discretion, if you choose to take advantage of these features.

LUCI OFFERS POWER WHEELCHAIR RIDERS MODERN MOBILITY®



ENHANCED MOBILITY PLATFORM

Individualized, not average
Independence, not autonomy

Enhanced mobility platform: The goal of LUCI is to provide power wheelchair users enhanced mobility that is tuned to them and increases their independence.



COLLISION AVOIDANCE

Dynamic obstacle detection that mitigates interference sources

Collision avoidance: LUCI's dynamic obstacle detection works in extremely tight environments. If LUCI determines you are driving toward a collision situation, the system will gradually slow you down, allowing you time to navigate safely around the obstacle. LUCI will slow and then stop the wheelchair if you attempt to run directly into a detected object.



DROP-OFF AND TIP PROTECTION

Edge detection
Unsafe slope warnings

Drop-off and tip protection: LUCI provides edge detection with an audible alert system for unsafe ground slopes. LUCI's advanced FusionSensors will allow you to drive on flat and sloped surfaces. LUCI manages the stability of your wheelchair in two ways.

- » **Drop-off avoidance:** LUCI will attempt to prevent you from going off a curb, stairs, or other drop-offs that would cause the wheelchair to tip over.
- » **Tip warnings:** LUCI will notify you with an audible warning beep and a flashing yellow light if you drive onto ground or ramps that could cause your wheelchair to tip over. LUCI includes a tip-over alarm, which will sound a loud, high-pitched audible alarm in the event the wheelchair tips over, to alert others to help you.



CLOUD-BASED COMMUNICATION AND ALERTS

HIPAA secure notifications
iOS, Android and Web Apps
Integration of user health data

Cloud-based communication and alerts: LUCI collision avoidance, drop-off avoidance and tip protection will operate without any network connection. LUCI is designed to connect to Wi-Fi when possible, and will use a cellular connection for high priority alerts when Wi-Fi is unavailable. The connection is used to send data to your personal profile on MyLUCI®. It is also used to send secure alerts to any authorized contacts and caregivers you have designated. All information is de-identified and encrypted before it is sent, ensuring your data is safe and secure.



HOME ASSISTANT COMPATIBILITY

Linked to MyLUCI® account
User guide level support

Home assistant compatibility: LUCI is compatible with Alexa and Google voice assistants, which can be used to get status updates on everything from intervention statistics and battery level to setup, troubleshooting, and frequently asked questions.

LUCI HARDWARE

A smart power wheelchair has integrated or retrofitted technology that provides enhanced, independent mobility to a wheelchair user, user health and wellness data collection capabilities, and connectivity to integrate with the connected world. LUCI turns your existing chair into a smart wheelchair.

LUCI consists of the SmartFrame™, LuciLink® Hub, Dashboard and Scout™ which are all mounted to your wheelchair. Additionally, your LuciLink® Wheelchair Key™ connects wirelessly to LUCI.

The SmartFrame is a metal frame that attaches between the seat and the base of your wheelchair and positions multiple FusionSensors™. We call them FusionSensors because they include multiple sensor types (radar, ultrasonic, cameras) around the SmartFrame to give overlapping coverage. There isn't one type of sensor that can catch all the potential dangers that a wheelchair user might encounter - from curbs to walls to couches, a single type of sensor just isn't enough.

The FusionSensors constantly monitor your surroundings for hazardous situations, including collision and drop-off dangers. You'll need to keep these sensors clear, so that LUCI can see.

The Scout, a forward-facing FusionSensor attached to your footplate, provides the front line of defense in this beautiful, dangerous world.

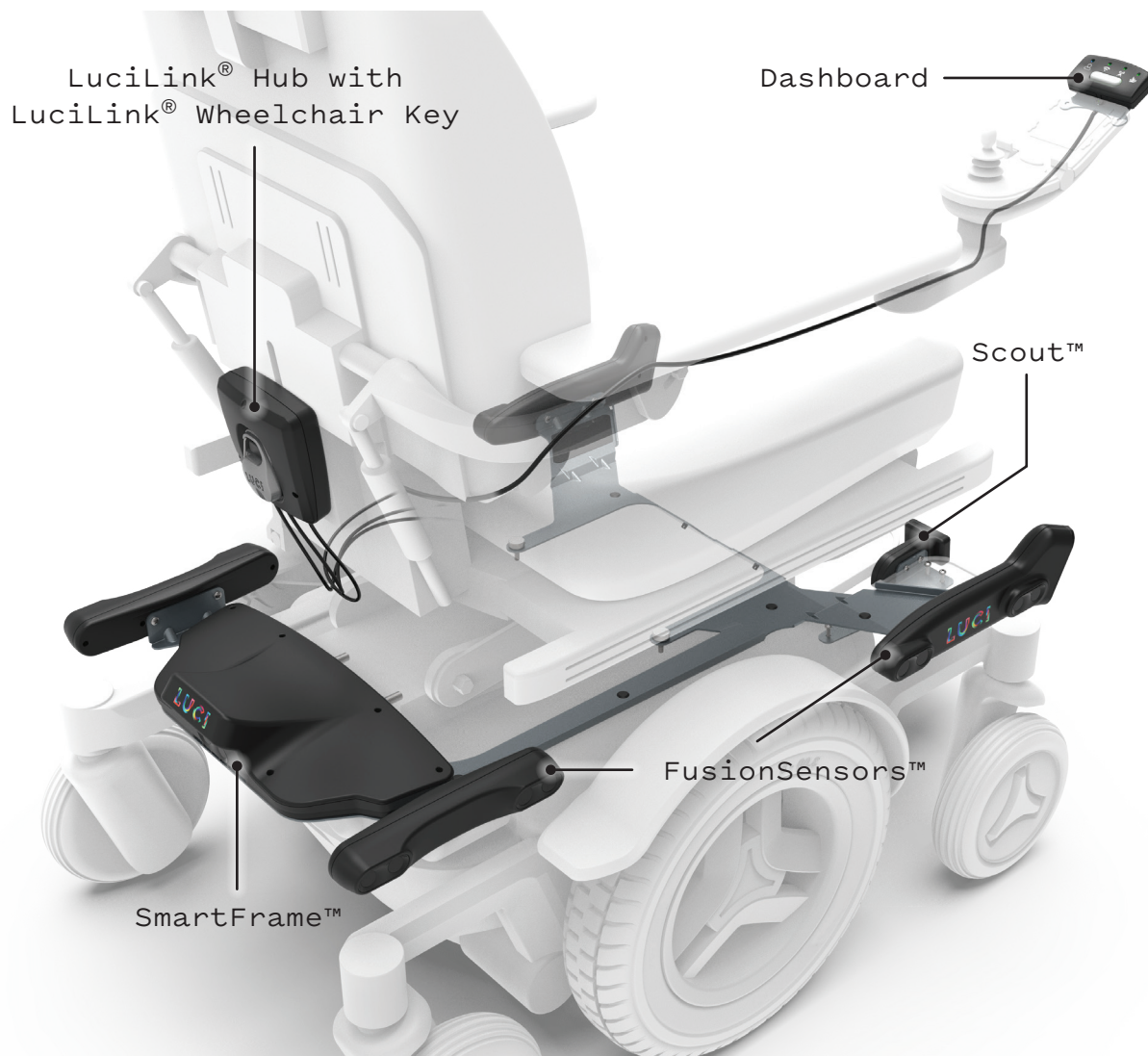

LUCILINK[®] HUB AND WHEELCHAIR KEY

The LuciLink[®] Hub is the USB data highway of LUCI. It is located on the back of your wheelchair seat. Only LUCI-compatible devices should be plugged into the LuciLink[®] Hub, and the hub enclosure should be securely closed while the wheelchair is in use to keep dust and water out.

When LUCI is installed and setup for you, your individual capabilities and preferences are linked to your MyLUCI[®] account with a LuciLink[®] Wheelchair Key.

Keep your LuciLink[®] Wheelchair Key with you when you are using LUCI so that LUCI can send information to MyLUCI[®] and so that you can change settings on your LUCI unit. LUCI's collision avoidance, drop-off protection, and tip protection will work with or without your LuciLink[®] Wheelchair Key present but you will not be able to change settings on your unit without the wheelchair key. In addition, information, including alerts and history, will not be sent to MyLUCI[®] from your LUCI unit without your Wheelchair Key present. For more information on how the LuciLink[®] Wheelchair Key helps protect your data and privacy, see the LUCI Privacy and Security report at luci.com/data.



You'll know that LUCI has detected your LuciLink[®] Wheelchair Key when the Personalized Status light on the Dashboard is illuminated solid green. Your LuciLink[®] Wheelchair Key connects to LUCI through Bluetooth Low Energy (BLE) and should be kept within about 3 feet (1 meter) of LUCI for the best, most reliable connection.





Keep your Wheelchair Key attached to your wheelchair or on your person. The Wheelchair Key contains magnets so that it can securely attach to the LuciLink[®] Hub on the back of the wheelchair. Alternatively, you can use the clip to attach it to your wheelchair or other belongings you keep with you. If you typically use backpacks or hang other bags off your wheelchair, you should clip the LuciLink[®] Wheelchair Key to a different location on the wheelchair to avoid knocking it out of its magnetized place on the LuciLink[®] Hub.

If the Personalized Status light on the Dashboard begins to blink green or doesn't light up with the key nearby, you should replace the LuciLink[®] Wheelchair Key battery as soon as possible. The battery is designed to last two years or more. When it needs to be replaced, please use a type CR2450 battery.

If you lose your Wheelchair Key, don't worry. The Wheelchair Key does not store personal information. As soon as possible, contact the LUCI Customer Experience Team to get a new LuciLink[®] Wheelchair Key.

DASHBOARD AND LUCI BUTTON

The Dashboard is your main interface for LUCI. The Dashboard is located on your wheelchair's control panel and has four indicator lights. Each light has a symbol below it, indicating its meaning. These meanings are detailed in the table.

LIGHT	DESCRIPTION	INDICATION
	Personalized Status	<p>Solid Green – LuciLink® Wheelchair Key detected, LUCI is able to send data to MyLUCI® and you can update your drive settings</p> <p>Flashing Green – LuciLink® Wheelchair Key has low battery</p> <p>No Light – No LuciLink® Wheelchair Key detected or your LUCI unit is not set up for you.</p>
	Wi-Fi Connection Status	<p>Solid Green – LUCI is connected to Wi-Fi network</p> <p>Flashing Green – Software update in progress (keep wheelchair powered off)</p> <p>No Light – No Wi-Fi connection</p>
	Cellular Connection Status	<p>Solid Green – LUCI is connected to cellular network</p> <p>Flashing Green – Software update in progress (keep wheelchair powered off)</p> <p>No Light – No cellular connection available</p>
	LUCI Status	<p>Solid Green – All sensors operating as intended</p> <p>Solid Yellow – Caution, something is close to your chair. If the light is on when not expected, you may have a blocked sensor (check for hanging bags or clothes) or you may have a dirty camera lens (wipe clean with a damp cloth).</p> <p>Flashing Yellow – Caution, you are on steep ground and should be careful. This light is accompanied by a beeping sound, which becomes more insistent as the slope gets steeper.</p> <p>Dim Yellow – The chair has not been set up yet or is in Demo Mode. A dim yellow LUCI Status light means LUCI is off, but ready to be activated if the LUCI Button is pushed.</p> <p>Solid Red – Error, chair should be turned off and back on if the red light stays on for more than a few seconds.</p> <p>Flashing Red – You are on dangerously steep ground or your chair has tipped. This light is accompanied by a fast beeping sound.</p>



The LUCI Button on your Dashboard can perform many functions, from Override, to launching the LUCI Setup Tool, silencing sounds, and even sending information to our team.

Note: A momentary switch plugged into the auxiliary jack on top of the Dashboard will mirror the LUCI Button functionality, except for launching Setup Mode.

If the LUCI Button is:

- » **Solid Blue** – LUCI is engaged
- » **Flashing Blue** – Override has been engaged
- » **Fast Flashing Blue** – LUCI Setup Mode has been engaged
- » **Not Lit** – LUCI is not engaged

Override: Short Button Press

- Override ON and OFF

Silence: Three Short Button Presses

- Silence LUCI sounds until the chair is restarted or until another triple press

Report: Five Short Button Presses

- Sends LUCI challenge info to the design team. Press this if LUCI stops you when it shouldn't.

Setup: Long (4 second) Button Press

- Enables LUCI Setup Mode when pressed
- Wheelchair controls are disabled in Setup Mode

LUCI SAFETY

Our patented system combines stereo vision, infrared projector, inertial measurement unit (IMU), ultrasonic, and radar data into a single view of the world, enabling never-before-seen possibilities for power wheelchair riders. LUCI uses multiple types of sensors to identify and cross-check potential obstacles. The data from these sources is fused and analyzed to ensure the safety of the surroundings.

COLLISION AVOIDANCE: 360°

LUCI's sensor coverage is best illustrated from a bird's-eye view. In the image:

- » **light blue** represents coverage by the stereo vision cameras,
- » **purple** represents radar coverage and
- » **green** represents ultrasonic sensor coverage.

You can easily see: LUCI has you covered.

LUCI is here to help and is constantly getting better. But as a driver, stay alert for:

- » Overhangs, like countertops, shelves and tables
- » Obstacles shorter than 3-4 inches (8-12 cm) off the ground
- » Single step-ups or obstacles (e.g., parking blocks) that may be within your chair's published curb climbing ability/limits
- » Uneven terrain outdoors

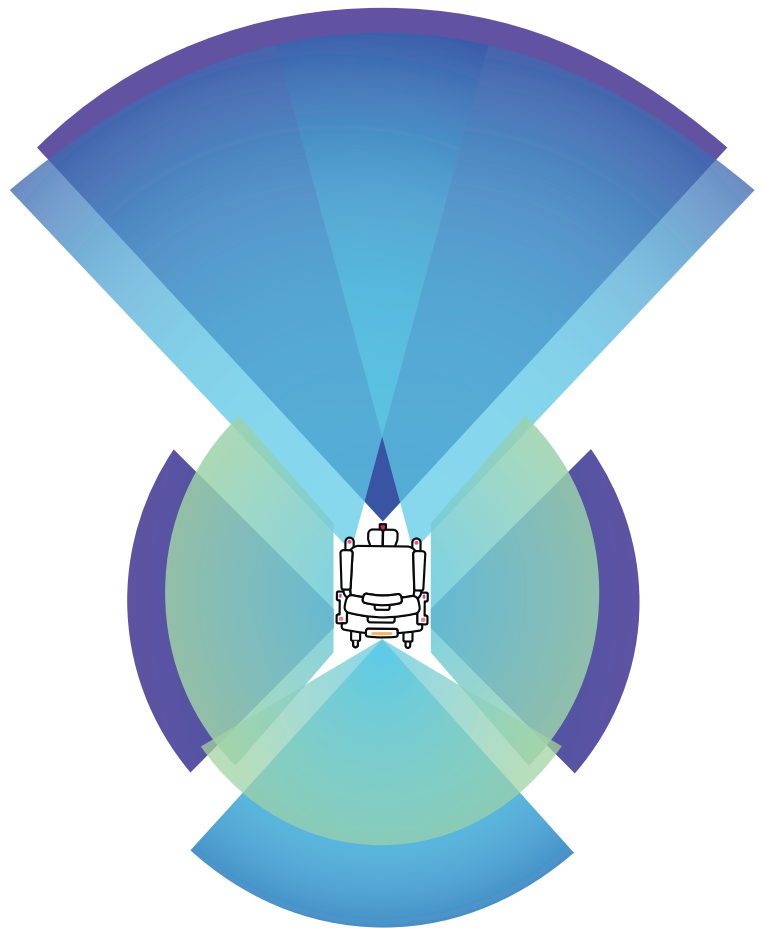

Essential Performance

The function of the system is defined as obstacle avoidance and audio/visual tip alert on the wheelchair. A wheelchair without LUCI has a high likelihood of the hazards LUCI mitigates. The essential performance of the system requires that LUCI not create unintended motion of the wheelchair and that LUCI alert the user to detected unsafe conditions. No user maintenance is required to maintain basic safety or essential performance.



COLLISION AVOIDANCE: FRONT & BACK

LUCI can see more than 15 feet in front and 3 feet in back as shown below. LUCI will not limit the wheelchair's capability to climb smaller curbs and slopes. This means that LUCI ignores items below your ground clearance like door thresholds, ramps, and uneven sidewalks.

Each chair manufacturer specifies a certain safe curb height. LUCI allows your chair to operate within its published climbing ability.

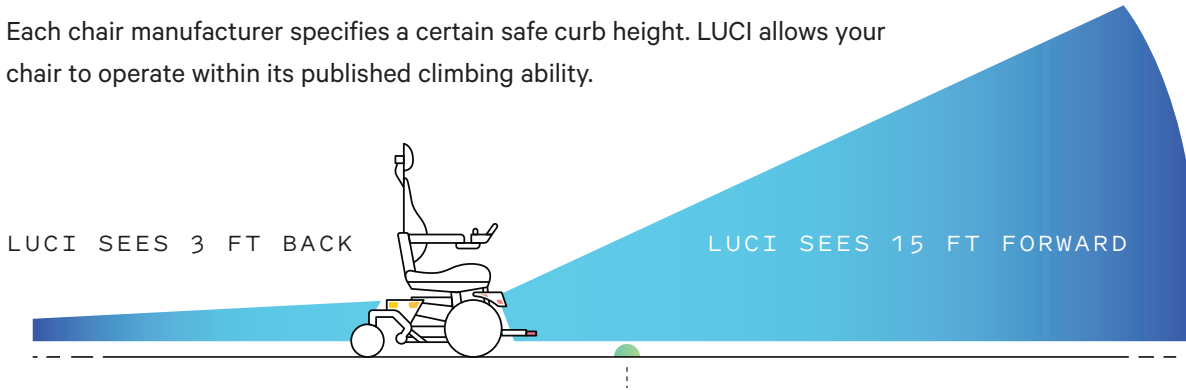

LUCI's collision avoidance intentionally does not limit the chair navigation for obstacles above the power base of the chair. This allows LUCI to still pull into open spaces like tables or desks. However, if you want LUCI to stop your chair at the same spot under a table every time then you can place an object under the table (like a box).

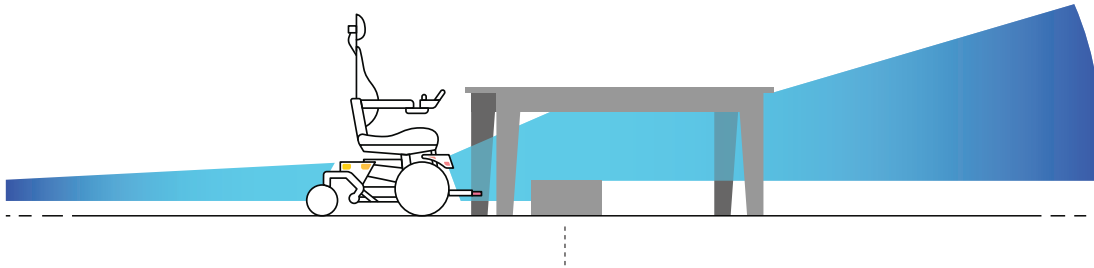

COLLISION AVOIDANCE: SIDE TO SIDE

Side sensor coverage is like the front-back coverage. LUCI will see a person's legs, but not their toes. LUCI will see a wall but not an overhanging object like a wall shelf, doorknob, or handrail. It is important to know that, based on user feedback, LUCI is tuned to get close to things on the side, even sometimes lightly scraping the armrest, depending on how wide the seating assembly is set.

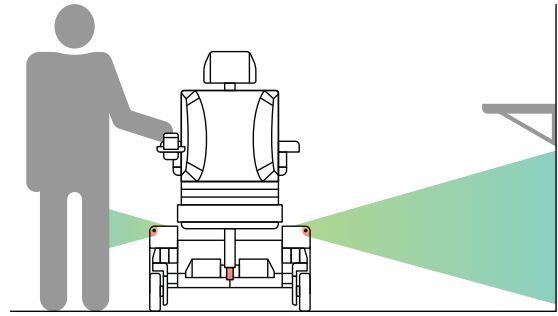

COLLISION AVOIDANCE: WHAT SCOUT SEES

LUCI's sensor coverage changes with the seating assembly position, specifically with the height and angle of the Scout. The fact that the Scout moves with the seating assembly is a good thing! The picture below on the left shows a wheelchair with the Scout low and pointed straight at a ramp. The light blue indicates camera collision coverage; notice that it is limited so that LUCI's cameras won't see the ramp as an obstacle and stop you from going up it. The pink indicates the Scout collision coverage, which may identify the ramp as an obstacle. The dark purple is where camera and Scout coverage overlaps. If you tilt the seating assembly or elevate the legrest, the ramp should no longer register as an obstacle for the Scout as shown below on the right.

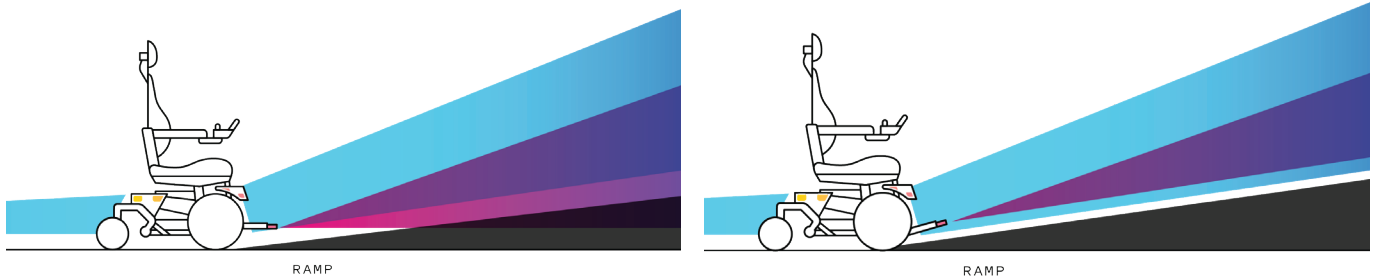

This same behavior impacts LUCI's ability to see speed bumps, parking blocks, and other ground objects in front of the chair. If, as shown in the image below on the left, the seating assembly is in a low position, the Scout is in line with an obstacle, and the radar can detect it, then LUCI will slow the chair. However, as the seat height is raised, the Scout is also elevated off the ground, and LUCI's ability to see low objects decreases accordingly.

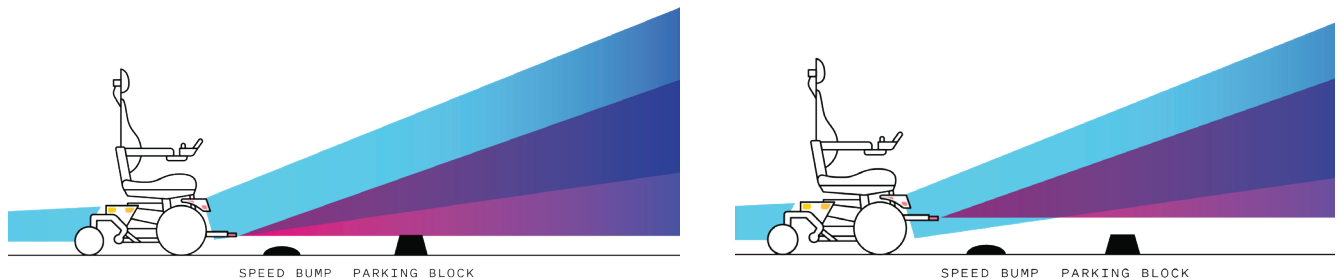

DROP - OFF PROTECTION

LUCI helps manage the stability of your wheelchair by monitoring ground features for curbs, stairs, or other drop-offs that would cause the wheelchair to tip over based on the published curb capability of the base wheelchair. LUCI will allow you to drive down small steps (~2-4 inches for most wheelchairs, depending on make and model) which are within your chair's specified capability, but will monitor for dangerous curbs and steps. LUCI is here to help and is constantly getting better. But as a driver, keep in mind:

- » Drop-off protection is similar to emergency braking, pedestrian detection, or airbags in an automobile. Please don't test it on purpose. It is there to add an extra layer of protection and it has limitations due to the wide variety of surfaces and environments a wheelchair rider may encounter.
- » LUCI will only detect and stop you on steps with a height greater than your wheelchair's published step threshold. LUCI will not stop you when the curb or drop-off is within your chair's specified capability. See your wheelchair user manual for the published step threshold.
- » If you drive at high speed settings toward an unsafe drop-off, LUCI may not be able to overcome your momentum to stop you in time.

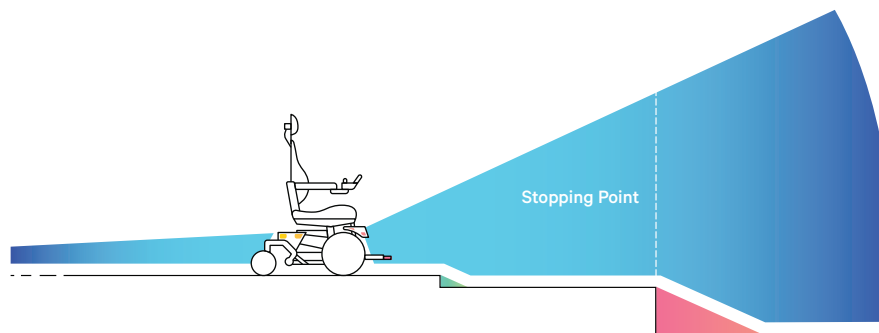

GROUND CONFIDENCE

LUCI's ground confidence algorithm adds an extra layer of protection to keep you safe while driving on uneven terrain. The ground confidence system checks ground data at approximately 2 meters from the chair and if the ground can't be clearly made out by the sensors it slows the chair down to a walking speed. This slowing gives LUCI's drop-off protection more time to react if it turns out that there is unsafe ground ahead. The speed allowed when ground confidence is triggered was selected so that the chair can still effectively maneuver in situations where shiny floors or other false positives might cause unreliable ground data. As with all LUCI's features, the goal of ground confidence is to provide feedback and the time you need to navigate your environment safely and successfully.

TIP PROTECTION

To help mitigate the effect of ground conditions, LUCI includes tip protection warnings to alert you if you are driving on unsafe slopes. LUCI uses onboard sensors to notify you with an audible warning beep and flashing light on the Dashboard if the wheelchair is on a slope that is greater than the maximum recommended slope for the wheelchair, based on the wheelchair manufacturer's recommendations. As the slope becomes steeper, the beeping becomes more insistent. If your wheelchair does tip over, LUCI will sound an audible alarm, the LUCI Status light will flash red, and LUCI will stop all motion. You can also use MyLUCI® to have a Tip Alert sent to another person.

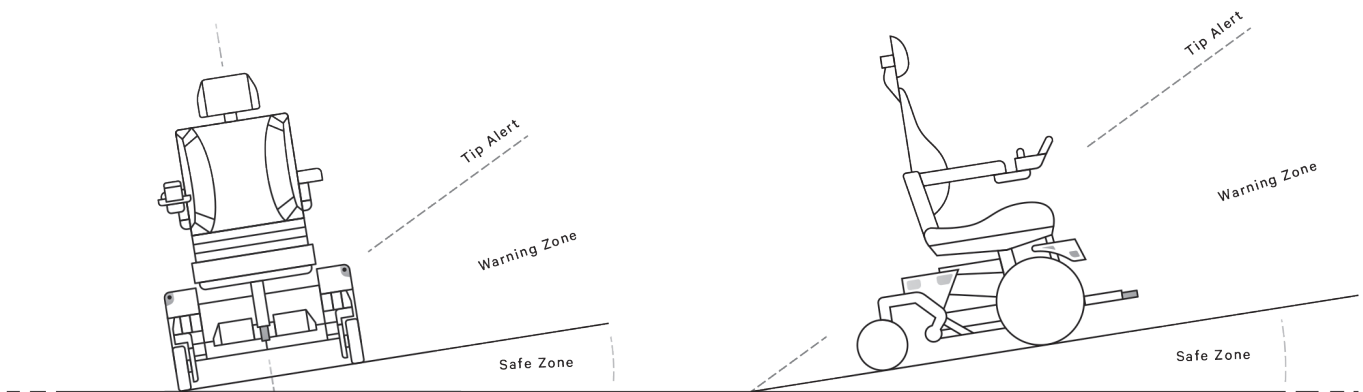

LUCILINK REMOTE STOP

LUCI's safety system opens new options for driver training, but sometimes it's good to have a remote stop option too. Most USB A Wireless Presentation Remotes, plugged into the LuciLink Hub, will function as a wireless emergency stop remote when either of the slide advance buttons are pressed. Pressing the slide advance button will cause a temporary E-stop on the wheelchair and stop chair motion until the joystick (or other drive method) is released just like any other remote emergency stop switch.

i **SETUP:** When using a new presentation remote with this feature, you should test the device compatibility, effective range, and e-stop timing after the button is pressed prior to using it as a training aid with a driver in the wheelchair. Test both short and long presses on the slide advance buttons as part of this check.

! **CAUTION:** LUCI will NOT notify you if the presentation remote is turned off, is out of battery, or if you are outside the effective range of the wireless remote.

THINGS TO KEEP IN MIND

LUCI's collision avoidance, drop-off protection, and tip protection are parts of LUCI's safety system. It is important to keep several things in mind when using LUCI:

- LUCI is not a replacement for wheelchair skills training.
- LUCI's sensors are not only the only ones in the industry, they are best-in-class in any industry; but just like the sensors on cars, trains, and airplanes, that doesn't mean that they can see everything.
- A wheelchair, like all motorized vehicles should be operated with an awareness of the dangers in the environments of use.
- LUCI's collision avoidance, drop-off protection, and tip protection never add to your joystick input, it only reduces your drive inputs to the wheelchair.
- To prevent tipping the wheelchair and/or throwing you out of the chair in an avoidance maneuver, LUCI does not apply emergency braking.
- LUCI's calculations incorporate your reaction time in the hope that LUCI won't need to completely stop the motion of the wheelchair. When LUCI is working best for you, it is assisting you to drive safely and smoothly in situations you might not otherwise be able to navigate successfully, by keeping the world within your ability to react to it. A user with a faster reaction time will find that LUCI speeds up and slows down more rapidly than it does for a user with a longer reaction time. LUCI keeps the human in the loop.
- Sloped ground and high speeds cause momentum that can prevent LUCI from completely stopping a wheelchair before colliding with a detected object. Once LUCI detects anything, however, you will be 'assisted' in a response, by slowing the wheelchair.

For more information on what LUCI sees, how Scout works, videos, and our latest Safety Report, visit luci.com/safe.

LUCI DRIVER ASSIST

LUCI Driver Assist features actively help you drive by redirecting or adding to your drive input to the wheelchair. All features listed below are optional, off by default, and must be explicitly turned on in the LUCI Setup Tool (see the section titled Updating Your Drive Settings). Driver Assist feature availability varies by wheelchair make, model, and configuration. Check the Setup Tool to see which features are available on your unit.

i LUCI Driver Assist features are designed to operate under the assumption that the driver is alert and monitoring the motion of the wheelchair.

When using Driver Assist features keep in mind:

- » If a Driver Assist feature activates and you do not wish to use it, press the LUCI button on the Dashboard to cancel assistance.
- » If at any point you do not like the action of a driver assist feature, simply let go of the joystick or other drive method to stop motion of your wheelchair. All LUCI Driver Assist features require active user input to operate.

RAMPASSIST™

RampAssist makes navigating up and down ramps easy. When enabled, LUCI will recognize ramps that have been marked with LUCI TAGs and will automatically drive you up and down the ramp using the same technology that is used to dock spaceships to the International Space Station (ISS).

RampAssist works in three easy steps:

1 **STEP 1: TAG YOUR RAMP**
RampAssist will only engage where you tell it to by putting LUCI TAGs down. The extra information from the TAGs provides more accurate navigation and chair speed information so that LUCI can drive with confidence.

2 **STEP 2: LUCI SEES A TAG**
LUCI's front cameras are constantly searching for TAGs. Park close to the bottom or top of the ramp where LUCI's front cameras can see a TAG and wait for RampAssist to engage. You'll know RampAssist is active when LUCI says "Starting RampAssist" and the green lights on your Dashboard begin to chase.

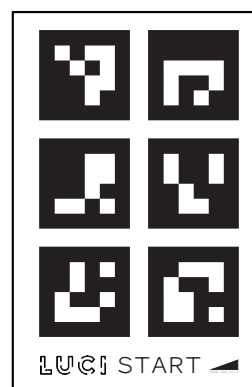

3

STEP 3: HOLD FORWARD

All you need to do is hold forward on your joystick or alt drive while LUCI drives you up the ramp. LUCI drop-off protection and collision avoidance safety features are still active while LUCI is driving. If you let off the joystick, your chair will stop moving and if you press the LUCI button you will exit RampAssist. You will know RampAssist is no longer active when the lights on the Dashboard stop chasing.



THINGS TO KEEP IN MIND

- You may still need to manually tilt your seat back or raise your leg rests before going up or down a ramp so they don't scrape the ramp before giving drive permission to RampAssist.
- If LUCI is not sure something is safe to automatically maneuver, it will cancel RampAssist and you will need to finish driving without RampAssist.
- As there is a limit to the degree of accuracy and control performance that RampAssist can provide, do not overly rely on this system. The driver is always responsible for paying attention to the wheelchair's motion and surroundings. Let off the joystick if you experience any unexpected behavior.
- RampAssist assumes properly installed TAGs on safe, structurally sound ramps that meet the requirements of your power wheelchair.
- RampAssist will not function on ramps that are narrower than your wheelchair base.
- RampAssist relies on cameras to operate. Therefore, lighting conditions, glare, and reflections may limit functionality. RampAssist may not work on certain ramps (particularly very shiny metal ramps) unless dulled with grip tape or paint. If equipped, use of headlights in dark environments will help RampAssist see TAGs more clearly.

To get TAGs for your ramp and learn more about the functionality and limitations of RampAssist visit luci.com/RampAssist.

i MAINTENANCE: If LUCI is struggling to recognize TAGs on your ramp you may occasionally need to wipe off dirt and debris from the TAGs with a damp cloth.

! CAUTION: Reposition or replace TAGs if they are no longer properly positioned, they show a high degree of wear, or if LUCI is starting to have a hard time recognizing them.

DRIVING WITH LUCI

Driving with LUCI is different than driving without LUCI. For experienced users and experienced clinicians/technicians, it can take a little time to get used to it. LUCI allows for some interesting “life hacks” in your home or work. Here are some new thoughts about driving with LUCI to help everyone succeed.

LET LUCI WATCH YOUR SPEED

LUCI offers a new way of working with the speed settings on your wheelchair. In the past a lot of time was spent figuring out what speed settings make the most sense for a user in a specific environment. For example, users were trained that home driving might be best at “Indoor 3” speed but driving down a sidewalk was best at “Outdoor 2”. LUCI regulates your speed for you, making these decisions a lot easier. Most LUCI drivers will pick their fastest preferred speed (say Outdoor 3) and then leave their speed at that setting all the time. LUCI is tuned to your reaction time instead of an arbitrary speed setting.

NOTE: The one place that this changes is if you are going to use the override feature of LUCI. In that case, make sure to turn your speed down in tight or difficult settings or use the Setup Tool to set a slower speed while Override is active.

CROWD MODE

You can use LUCI to follow another person’s lead. Try it out by having someone stand in front of your wheelchair and press forward on your joystick. When the person starts walking, your wheelchair will follow at their pace as they speed up or slow down. LUCI’s collision avoidance capabilities can also be used to match the pace of a crowd without changing your speed manually.

IT’S OKAY TO OVERRIDE SOMETIMES

Sometimes you’ll need to push things open with your footplate. Sometimes you’ll need to pull in and touch the dash when you get in your van, sometimes you’ll want to jam the chair up against something for transfer. In all these situations LUCI is going to stop you short and it’s ok to use override. The Dashboard, located just above the joystick on the wheelchair control panel includes a LUCI Button, which can be used to temporarily override LUCI. This button should only be pressed in situations when LUCI sees a danger that you know to be false, allowing you time to navigate the situation without LUCI’s assistance. When this button is pressed, the blue light will blink for 30 seconds, 60 seconds, or until the button is pressed again (this setting can be updated in the MyLUCI® app or in the Setup Tool). During this time, LUCI is temporarily disengaged, and you should take extra precautions to ensure your personal safety.

USE THE BLOCKED SENSOR INDICATOR TO HELP YOU DRIVE

When the LUCI Status light on your Dashboard turns yellow, that means something is very close in the direction you are trying to drive. If you're not near something, it might be a blocked sensor. If you're driving and the light turns yellow, there might be something in your way that you can't see. Check to see if there are clothes, bags, or other items hanging in front of a sensor. The indicator is intended to help you know what LUCI is seeing.



DESIGN YOUR SPACE FOR LUCI

LUCI will slow your wheelchair down and stop it for detected objects. So take advantage of that feature and try moving furniture or placing boxes or obstacles in your home so that LUCI stops you in the same place every time next to a transfer location or a favorite spot. If you have a corner or tough location to maneuver in your house you may actually be able to make it easier to maneuver by placing obstacles along the sides that will guide your chair thanks to LUCI's collision avoidance feature. We've seen users come up with some pretty clever LUCI hacks with furniture, blankets, boxes and more. Try it out!

WITH YOUR HELP LUCI GETS BETTER

Unlike your current wheelchair, LUCI will get better with time. LUCI is wicked smart, but the world is a complex place. We're continuing to make LUCI better. As long as your LUCI unit is connected to Wi-Fi, you will get the latest software updates and improvements automatically. But we need to know what to improve, so please press the LUCI button five-times when you find an issue or challenging situation to send the data to our development team.

MYLUCI®

MyLUCI® is an app that gives you access to your data and allows you to securely share data with your team. To set up your MyLUCI® profile, simply follow the instructions that were emailed to you when LUCI was first installed and set up on your wheelchair. You can access MyLUCI® by downloading the MyLUCI® app on the Apple App Store or Google Play Store. In the MyLUCI® app, you can:

- Share data and information with your contacts and caregivers
- Use LUCI View for a bird's eye view of your surroundings
- Change wheelchair boundaries and other common settings
- Access health information from LUCI-compatible devices
- And much more!

DATA PRIVACY

We take data security very seriously. To this end, we've taken many steps to ensure data privacy. No personally identifiable information is stored on LUCI units locally. All information is deidentified. The MyLUCI® portal is HIPAA-secure and kept up-to-date by our team. Even though day-to-day communications between LUCI and the cloud don't include personally identified information, we transmit deidentified and encrypted data via a secure connection to MyLUCI®. Your LUCI unit will not send data to MyLUCI® unless your personal Wheelchair Key is present. For more information, visit luci.com/data.

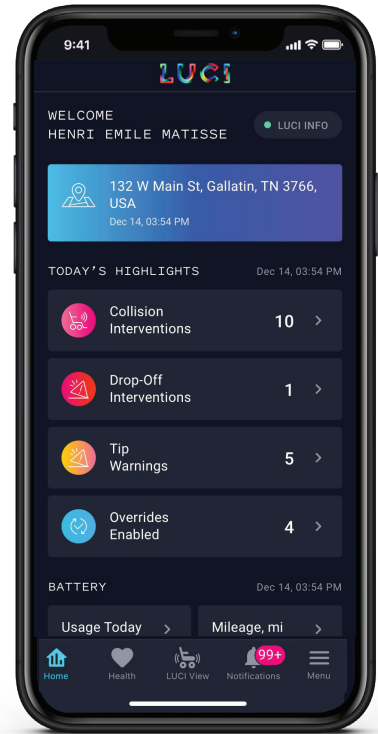

SUPPORT TEAM



Within the MyLUCI® app, you are able to add contact information for your Support Team. Add caregivers and loved ones, enter their contact information, and choose what data you would like to share with each individual. These contacts will be sent an email, inviting them to MyLUCI® and your team.

LUCI VIEW

Within the MyLUCI® app, you have access to a 360-degree visualizer tool that allows you to see what LUCI sees. Tap on LUCI View in the menu and your phone will automatically connect to your LUCI unit while your chair is on.

The LUCI View visualizer will show you where the nearest drop off (white box) and collision (black dot) obstacles are located, relative to your chair. It will also color zones in red if motion is stopped because of an obstacle at the wheelchair boundary, yellow for zones where an obstacle is approaching, and green for zones in which motion is unobstructed.

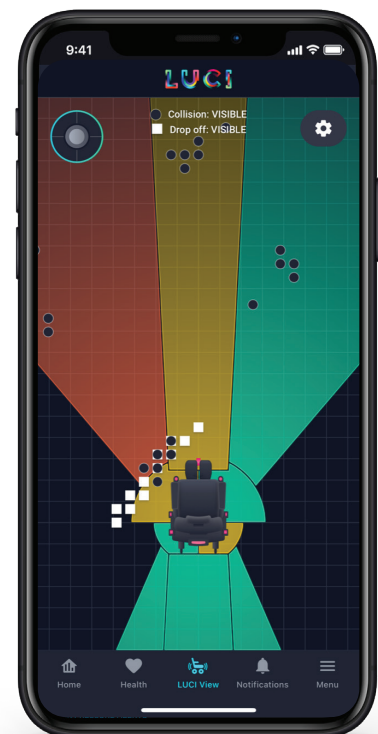

MYLUCI[®] HEALTH MONITORING

The MyLUCI[®] iOS and Android apps can connect to some health devices and allow you to monitor and share your heart rate data.

Tracking heart rate first became a goal of LUCI due to Katherine. She won't admit pain, and is tough as nails, so in an effort to better understand when she was in pain, we measured heart rate. Health tracking devices were available and when heart rate spiked, it was a good indicator that something was hurting Katherine. Since that time, we've learned how heart rate can be useful for other LUCI users and their teams.

Obviously, heart rate can be used to track exercise and fitness goals. But, here are a few things about heart rate we've learned:

- Heart rate spikes can happen for lots of reasons. In fact, your heart rate and respiratory rate can often signal fever, anger, stress, pain, and many other conditions.
- Heart Rate Variability (HRV) or how much your heart rate changes off of a baseline over time is a topic of much research for general health, and particularly for those fighting ALS or other progressive diseases.

You can log continuous or session heart rate data from a wearable to MyLUCI[®] in order to share the data with others on your team. MyLUCI[®] makes sharing your heart rate data from Apple Health or Google Fit with others easy and gives you full control of who can see your information.

An Important Note on MyLUCI[®] Health Data

We've chosen to integrate with Apple Health and Google Fit in an effort to work with as many consumer health devices as possible, in the simplest-to-use way possible. This means health tracking data through MyLUCI[®] isn't real-time. There may be delays as the data travels through Apple Health/Google Fit and into MyLUCI[®].

We want this information to be useful to you, but it is important to understand that any alert or data sharing functions on MyLUCI[®] are for convenience, not a replacement or alternative for continuous medical monitoring and real-time medical alarm systems.

For information about which health monitoring devices work best and how to connect them to MyLUCI[®], visit luci.com/health.

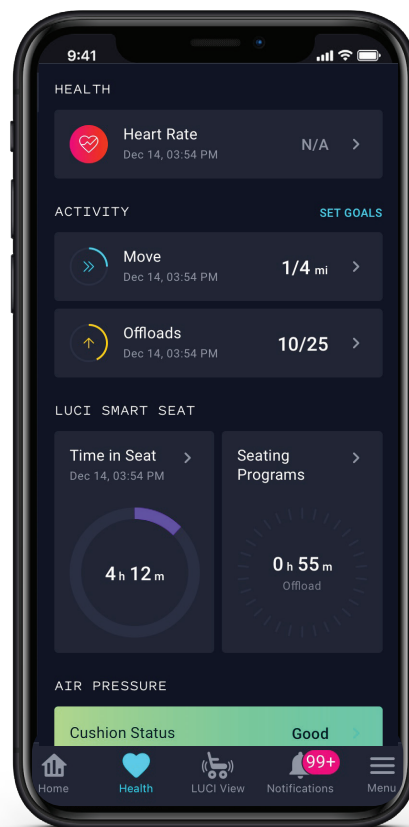

CONNECTING TO WI-FI

WHY AND HOW

LUCI works without an internet connection, but connecting LUCI to Wi-Fi has many benefits. A Wi-Fi connection ensures that you will always have the latest and greatest software. Over-the-air software updates can only be pushed to LUCI units that are connected to Wi-Fi. With a Wi-Fi connection, LUCI is also able to save your data to MyLUCI® and send alerts to contacts and caregivers at your discretion.

To set up a Wi-Fi connection, power your wheelchair on, open the MyLUCI® app and tap on **Menu**, then **LUCI Wi-Fi Networks**. Select the network you want and follow the prompts to connect. You will know you are connected to Wi-Fi when the Wi-Fi indicator light on the Dashboard is illuminated a solid green.

You can add Wi-Fi networks that aren't available locally (for example, setting up a home network while installing LUCI at a clinic) with this interface too. Just scroll to the bottom of the list of Wi-Fi networks and select "Add Other Network".

SOFTWARE UPDATES

In order to stay up to date with the latest and greatest software, LUCI receives over-the-air software updates. To complete these updates, LUCI must be connected to Wi-Fi. Updates are scheduled to occur while your wheelchair is off to minimize disruptions to your personal use. Every night, LUCI wakes up quietly without turning on your wheelchair and checks to see if there are any software updates available. If not, LUCI goes back to sleep. If there is an update available, LUCI checks if your wheelchair battery has enough charge, your wheelchair is off, and LUCI is connected to Wi-Fi. If all three of these are true, then LUCI will begin the update. While LUCI is updating, the Wi-Fi and Cellular indicator lights will flash on the Dashboard until the update completes.

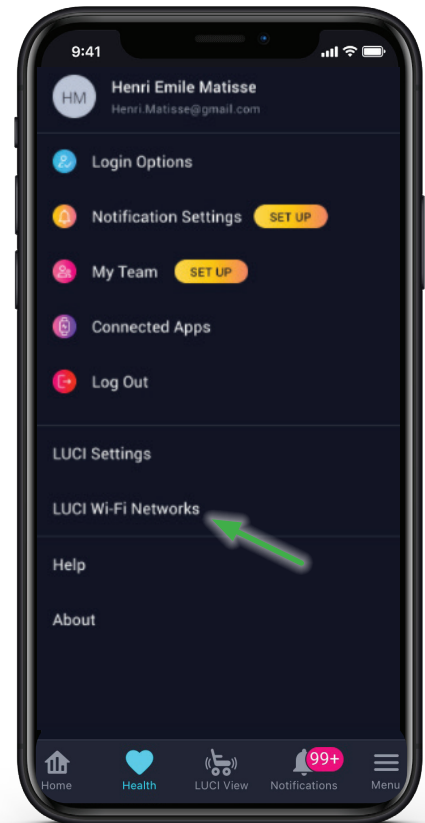

MYLUCI® VOICE

We are founded and led by committed members of the community of people living with disabilities and their caregivers. From the beginning, our team set out to make this world more accessible for Katherine, and for all people using power wheelchairs. Along the way, we have created a culture of intentional partnership, because technology is another area where inclusion matters.

As you explore LUCI's many capabilities, we are happy to offer integration with some of the most common voice assistants - Amazon Alexa and Google Assistant. When these capabilities are enabled, voice assistants can answer questions about the status of your wheelchair, help you access troubleshooting tips, and so much more!

USING ALEXA WITH LUCI



To connect your Alexa supported device with LUCI on your computer, follow these steps:

1. Log in to your Amazon account using a web browser and navigate to Alexa Skills.
2. Search for LUCI in Alexa Skills.
3. Select the LUCI skill and then select Enable on the skill.
4. You will be prompted to enter your MyLUCI® account name and password. Follow the instructions.

To connect your Alexa supported device with LUCI on your smartphone, follow these steps:

1. If you haven't already done so, download the Amazon Alexa app on your smart device.
2. Open the Alexa app on your phone or mobile device.
3. Select Skills & Games within More menu in the app.
4. Search for MyLUCI® and select the MyLUCI® skill.
5. Select Enable Skill on the skill page.
6. You will be prompted to enter your MyLUCI® account name and password. Follow the instructions.

You can now interact with LUCI on any Alexa-supported device that is linked to your Amazon account! LUCI supports nearly 100 different phrases and commands that Alexa can help with. When referring to LUCI, be sure to use the phrase “my LUCI” rather than just the name “LUCI”. A few examples of phrases you can use include:

Get started with:

“Alexa, ask my LUCI what kind of questions I can ask.”

- “Alexa, ask my LUCI if I need to charge my chair.”
- “Alexa, ask my LUCI what she’s been up to today.”
- “Alexa, ask my LUCI what that sound means.”

USING GOOGLE ASSISTANT WITH LUCI



To connect your Google Assistant supported device with LUCI on your computer, follow these steps:

1. Log in to your Google account online.
2. Navigate to Explore All Actions on assistant.google.com.
3. Search for the MyLUCI® skill.
4. Select Link.
5. You will be prompted to enter your MyLUCI® account name and password. Follow the instructions.

To connect your Google Assistant supported device with LUCI on your smartphone, follow these steps:

1. Open the Google Assistant app on your phone or mobile device.
2. Search Actions for MyLUCI®.
3. Select the MyLUCI® action.
4. Select Link.
5. You will be prompted to enter your MyLUCI® account name and password. Follow the instructions.

You can now interact with LUCI on any Google Assistant supported device that is linked to your Google account! LUCI supports nearly 100 different phrases and commands that Google Assistant can help with. When referring to LUCI, use the phrase “LUCI chair”.

Get started with: “Hey Google, ask my LUCI chair what kind of questions I can ask.” Then try:

- “Hey Google, ask my LUCI chair if I need to charge my battery.”
- “Hey Google, ask my LUCI chair what she’s been up to today.”
- “Hey Google, ask my LUCI chair what that sound means.”

Visit luci.com/alexa or luci.com/googleassistant for the full list of phrases and commands, troubleshooting, and more.

UPDATING YOUR DRIVE SETTINGS

LUCI settings can be changed when your Wheelchair Key is present by putting LUCI in Setup Mode. To get into Setup Mode, press and hold the LUCI button on your Dashboard. For your safety, while in Setup Mode, your wheelchair will not move.

BASIC SETTINGS

The most commonly used settings can be updated through the MyLUCI® app. Press and hold the LUCI button on your Dashboard until it beeps and begins to flash quickly. Then open the MyLUCI® app, tap on **Menu**, then **LUCI Settings**.

Here you can change:



Collision Avoidance

LUCI's collision avoidance is designed to help you navigate your world. Select your preferred collision avoidance behavior.

You can choose from:

- » Protect - LUCI will stop short of hitting detected objects and play a collision stop sound to let you know that you cannot travel any further in that direction.
- » Assist - LUCI will slow you down before hitting detected objects and play the collision intervention sound but will continue to let you travel in the direction of the object at a very slow speed.



Wheelchair Boundaries

Choose your Foot Zone (Standard or Extended) and Back Clearance (Standard, Extended, or Reclined). If LUCI is detecting objects in the front - like stretched out feet - or in the back - like an oxygen tank or reclined seating - extend the zone so your chair stops further from obstacles. For the majority of users, the standard settings are the right choice.



Override

When you turn your chair on, LUCI is on by default. If you disagree with LUCI you can push the LUCI button on the Dashboard to override LUCI. You can choose to have Override last 30 seconds, 60 seconds, until next button push, or until you stop moving.

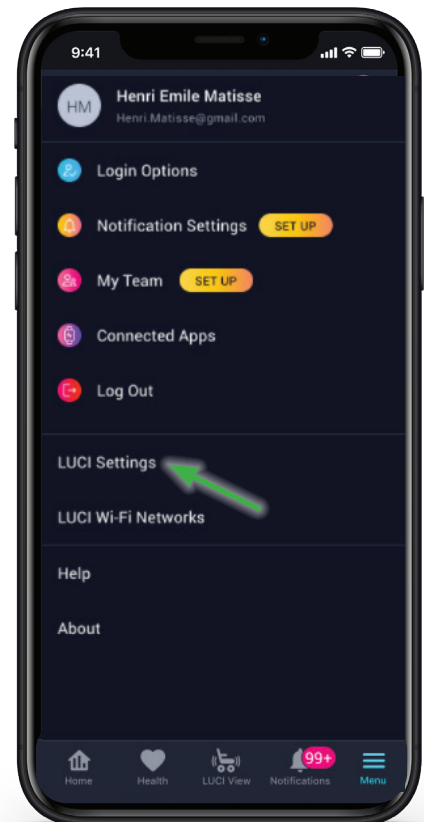

When you are finished, restart your chair.

ADVANCED SETTINGS

The LUCI Setup Tool allows you to update basic settings as well as many more. To access the LUCI Setup Tool:

1. Press and hold the LUCI button on your Dashboard until it beeps and begins to flash quickly.
2. Use your laptop, tablet, or smartphone to search Available Wi-Fi Networks and connect to the **LuciSetup-MMM-SSSSSS** Wi-Fi network, where MMM-SSSSSS is the three digit model and six digit serial number of your LUCI unit. The network password is: **LuciSetup**.

This will launch a Setup Tool window in your web browser. If for any reason the Setup Tool does not launch automatically, simply go to lucisetup.com. In the Setup Tool, you will be able to:

- » Update your Reaction Time
- » Change Wheelchair Boundaries
- » Access advanced Override settings
- » Enable or disable LUCI for attendant joystick
- » Update Sound Settings
- » Change Collision Avoidance mode
- » Enable or disable White Cane filter
- » Change Drop-Off Protection mode
- » Enable or disable features
- » Add and remove Wi-Fi networks
- » Find your LUCI model and serial number
- » Disable LUCI completely

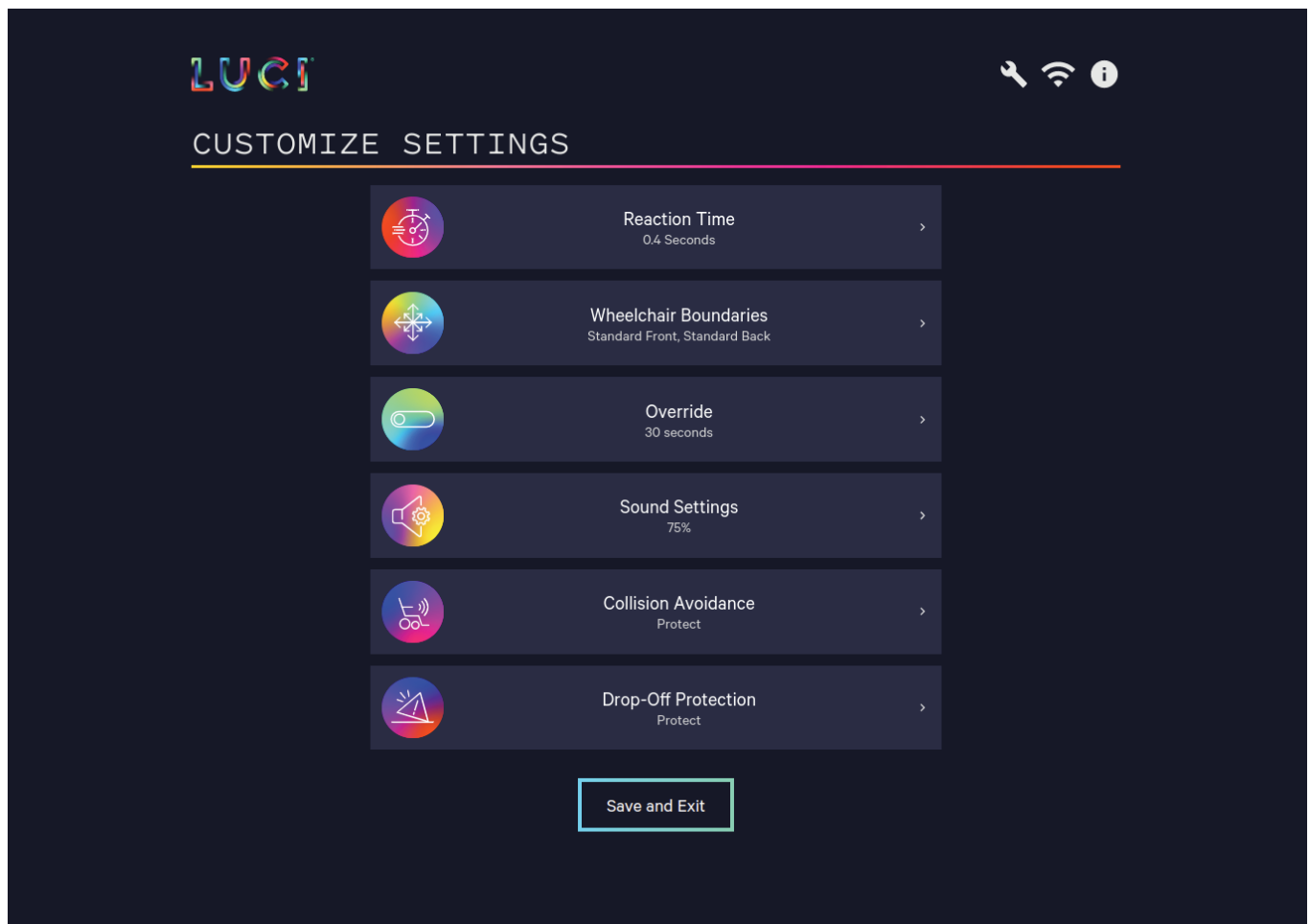

CARE AND MAINTENANCE

CLEANING

If needed, use a soft, clean, damp cloth to clean LUCI. Mild, nonabrasive household cleaners may be used. Do not use scouring powders or harsh cleaners as these can damage the finish on the system. Lenses may be cleaned with a soft, damp cloth.

Although LUCI will alert you if your sensors need immediate attention, it is a good idea to periodically check your camera lenses to make sure they are clean. Two lenses are located on the front left and front right of your wheelchair, just below your seat. A third lens is located on the back.

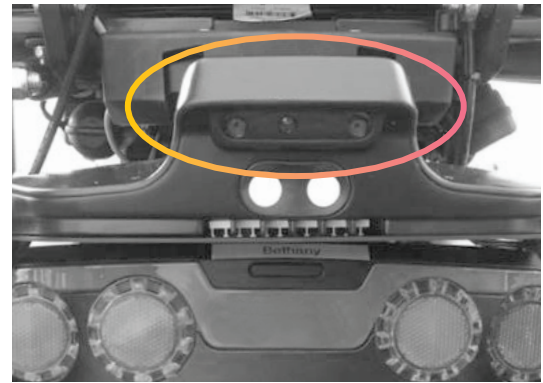
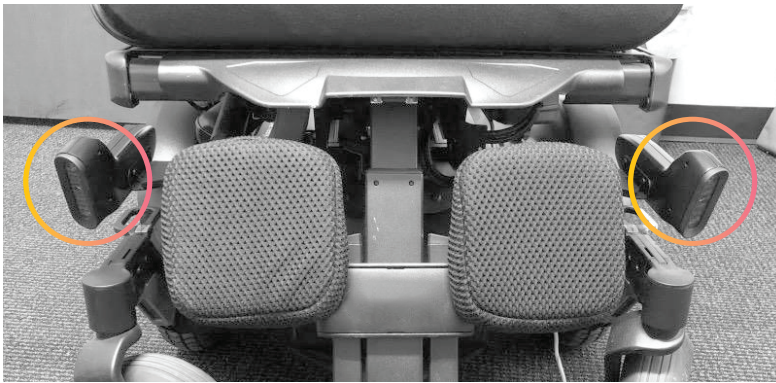

SERVICE

LUCI is designed to withstand normal wear and tear. Although we strive to ensure that you never have any problems with LUCI, it is possible that your system may need service. In the event of system damage, please contact the LUCI Customer Experience Team immediately for assistance.

Situations that warrant a call for immediate service may include:

- Damaged, pinched, or frayed cables
- Broken or open plastic housings
- Bent or twisted frame
- Solid, persistent red light on Dashboard LUCI Status, indicating sensor error
- Lost LuciLink® Wheelchair Key
- Damage to FusionSensors, Scout, or Dashboard

If you encounter these or other issues, please contact the LUCI Customer Experience Team immediately.

TROUBLESHOOTING

Generally, LUCI works like most other electronic devices: if you run into an issue, a good first step of troubleshooting is turning your wheelchair off and back on to restart LUCI. After that, use the Dashboard, LUCI Info in MyLUCI®, and this list of common problems to troubleshoot.

GET HOME SAFE MODE (AKA “LUCI IS TALKING”)

In some situations, you may hear LUCI say “Error deteted. Limiting movement and disabling LUCI.” This message may be accompanied by a solid or blinking red sensor Status light, or no lights on the Dashboard. Generally, this means a sensor error has occurred and Override cannot be used (for example, if the Dashboard USB cable is pulled out of the LuciLink® Hub). In this state, you will be able to drive your wheelchair at half speed (approximately 2 mph) and LUCI is not engaged. Get to a safe place and restart your wheelchair. Open the LuciLink® Hub and confirm that all cables are firmly plugged in. If the problem persists, contact the LUCI Customer Experience Team as soon as possible.

COMMON PROBLEMS

LUCI stops me sometimes at door thresholds or in parking lots.

Depending on how far your footplate is from the ground, the Scout radar may pick up metal thresholds and small pot holes as potential problems. To address this issue, make sure you are driving with your footplate/Scout pointed in the ideal footplate angle zone as shown in the image. Keeping the footplate/Scout parallel or slightly angled up from the ground drastically reduces false stops. If necessary, the Scout can be adjusted independently of the footplate to keep it at the ideal angle. If LUCI tends to stop on bumpy ground, it could be that LUCI is seeing your footplates or feet hopping in and out of the camera frame. Try extended footzone in the MyLUCI® app so that LUCI ignores a bit more of the area around your feet (see page 19 for instructions).

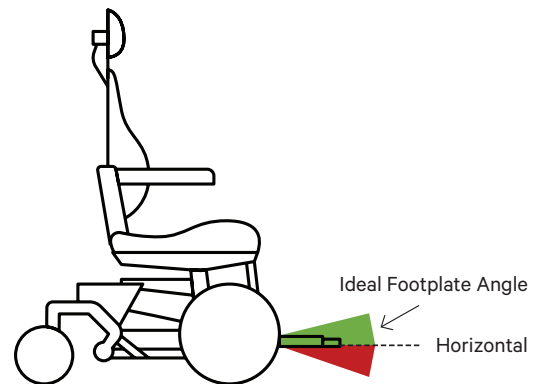

LUCI stops or slows me on a shiny floor or lighting transitions.

Floors with glare or shine on them (you can see the glare when you look at the floor) are a challenge for LUCI. We’re getting better and better at training LUCI to ignore glare, but the cameras interpret the glare as a hole in the floor and don’t want you to drive into the hole. Three approaches to getting past this problem:

1. If you turn a little the glare will be at a different angle and you should be able to drive forward.
2. You can use override to get past the shiny area.
3. If you are in a facility where the floor is shiny everywhere and there aren’t steps or ramps you are concerned with, you can disable just the Drop-Off feature through the LUCI Setup Tool (see page 20 for instructions).

LUCI stops me from driving up a ramp when I'm aligned.

Depending on how far your footplate is from the ground, the Scout radar may pick up a ramp as an obstacle (see the image below on the left). To avoid this (and to avoid dragging your footplate on ramps) slightly tilt your seating assembly back, extend your legrests away from the seat, or raise your seat, as shown in the image below on the right. Refer to page 10 for more information on What Scout Sees.



DRAGGING FOOTPLATE



RAISED FOOTPLATE









LUCI stops me too far away from things.

If you are often in very tight spaces, LUCI may stop you more aggressively than you'd like. If LUCI is stopping you too far away from objects (for example, if you need to get closer to a bed for a transfer), you might want to try Assist for Collision Avoidance. This mode will still slow your wheelchair as you approach an obstacle, but will then allow you to continue creeping forward as close as you want. Use the MyLUCI® app to update this setting (see page 19 for instructions).

If problems persist or if you encounter problems that aren't covered in this troubleshooting guide, call the LUCI Customer Experience Team at 615-813-LUCI, option 2.

If LUCI is having problems and preventing you from driving your wheelchair, and the LUCI Customer Experience Team is unable to provide an immediate resolution, follow the instructions on page 20 to disable LUCI until the problem can be resolved.

THE LUCI DASHBOARD

LIGHT	PROBLEM	MEANING	RESOLUTION
	Solid red light on LUCI Status	System Error	If the light stays on for more than a few seconds, use Override to get to a safe location, then turn your wheelchair off and back on. Check if there are any loose, unplugged, damaged or frayed cables on the Scout or if there is any physical damage to the cameras.
	Blinking red light on LUCI Status	System Error	If the light blinks for more than a few seconds, turn your wheelchair off and back on. Check if all the USB cables in the LuciLink® Hub are plugged in all the way.
	Solid yellow light on LUCI Status while LUCI is on	Blocked sensor or sensor needs to be cleaned	Check for loose clothing blocking sensors on the front, sides or back of the wheelchair. If LUCI will allow you to drive some directions but not others, there may be a blocked sensor in the direction in which you can't move. Check that the camera lenses on the front left, front right, and back of LUCI are clean.
	Blinking yellow light on LUCI Status	Wheelchair is on steep ground	Proceed with caution to avoid tipping. The light will be accompanied by a beeping sound. The light and sound will become more insistent as the ground gets steeper. If this happens when you are on level ground, try turning your chair off and back on to make LUCI's onboard orientation sensors recalibrate.
	Dim yellow light on LUCI Status while LUCI is off	LUCI is in Demo Mode and not engaged	To re-engage LUCI, press the LUCI Button.
	Flashing green or no light on Personalized Status	LuciLink® Wheelchair Key has low battery or battery is dead	Use a small Phillips screwdriver to open the LuciLink® Wheelchair Key and replace battery with a CR2450 battery.
	Green Cellular and Wi-Fi lights on or flashing while wheelchair is OFF	LUCI is checking for or installing a software update	Do not turn your wheelchair on. Wait for the lights to go off before using LUCI or powering on your wheelchair.
	Slow flashing blue light on LUCI Button	System override has been activated	Proceed with caution. LUCI will re-engage per your override settings or when the button is pressed again. Note: Length of override can be changed in the MyLUCI® app.
	No lights on Dashboard when wheelchair is turned on	Dashboard is not connected to power	If available, turn the main power breaker on the wheelchair off and back on to clear any disable commands sent to LUCI. Check that all USB cables are plugged into the LuciLink® Hub. If the problem persists, contact the LUCI Customer Experience Team for service.



WARNINGS & NOTIFICATIONS

1. LUCI's collision avoidance, drop-off protection, and tip protection are part of a driver assistance system. LUCI is not a replacement for wheelchair skills training.
2. A power chair should be operated with an awareness of the dangers in the environments of use.
3. Sloped ground and high speeds cause momentum that can prevent LUCI from completely stopping the wheelchair before colliding with a detected object. LUCI does not apply emergency braking, to prevent tipping the wheelchair and/or throwing the user out of the chair in an avoidance maneuver.
4. A wheelchair's actual tip limit may be different from the manufacturer's published limit due to seating assembly position, user weight, user positioning, attachments, or ground conditions.
5. LUCI is tuned to work with model default R-NET settings. Increasing top speeds and accelerations or decreasing deceleration in R-NET may prevent LUCI from stopping the wheelchair effectively.
6. LUCI should not be serviced while the wheelchair is in use. Service should only be performed when the wheelchair is powered off.
7. LUCI is intended to be mounted on a power wheelchair. Use of this equipment adjacent to or stacked with other equipment should be avoided because it could result in improper operation. If such use is necessary, this equipment and the other equipment should be observed to verify that they are operating normally.
8. All FusionSensors must have a clear line of sight to operate as intended. Avoid covering sensors with loose clothing, blankets, positioning belts, or other obstructions.
9. The LuciLink[®] Hub on the back of the wheelchair should be attached with the cables exiting from the bottom, to avoid potential water damage inside the hub.
10. Only LUCI compatible devices should be plugged into the LuciLink[®] Hub on the back of the wheelchair. No other devices should be plugged into the USB ports. Plugging in other devices may void the warranty and create unsafe operation of LUCI.
11. The auxiliary jack on the Dashboard is intended for connecting an alternative drive momentary switch to be used as a LUCI button. No other devices (headphones, etc.) should be plugged into the auxiliary jack.
12. LUCI is temporarily disengaged when in Override mode. Only press the LUCI button to override LUCI when you are certain you can safely proceed in the direction you wish to travel. LUCI includes a tip-over alarm even when override mode is engaged, which will sound an audible alarm in the event that the wheelchair tips over.
13. The Dashboard or momentary switch used to mirror the LUCI Button should be placed in a location where it will not be accidentally pressed.
14. LUCI is powered by the wheelchair battery. If the wheelchair isn't functional or the battery is out of power, LUCI will not be operational.
15. The LUCI SmartFrame™ is not intended to support any weight, including hanging bags, sitting, or standing. Hanging anything on or supporting any weight can damage the system and create unsafe operation of LUCI.
16. LUCI can handle any temperatures you can. The system is rated to withstand operating temperatures between -5°C and 40°C (23°F and 104°F) and storage temperatures between -40°C and 65°C (-40°F and 149°F). Storing or operating your LUCI-equipped wheelchair outside of these temperature ranges could damage the system and may void the warranty.
17. LUCI contains Class 1 lasers, very similar to the facial recognition lasers some phones use. These allow LUCI to maintain situational awareness even in dark environments. Don't look into the front or rear sensors when LUCI is powered on.

18. LUCI contains acoustic sensors that operate between the frequencies of 40 kHz and 60 kHz.
19. Use of accessories, transducers and cables other than those specified or provided by the manufacturer of this equipment could result in increased electromagnetic emissions or decreased electromagnetic immunity of this equipment and result in improper operation.
20. The LuciLink® Wheelchair Key and LuciLink® Hub on this product contain magnets.
21. Portable RF communications equipment (including peripherals such as antenna cables and external antennas) should be used no closer than 30 cm (12 inches) to any part of LUCI including cables specified by the manufacturer. Otherwise, degradation of the performance of this equipment could result.
22. All cables should be installed, bundled, and routed to avoid damage to the cables through pinching, dragging, etc. and to avoid excess cable length that could lead to entanglement or strangulation. Please contact the LUCI Customer Experience Team immediately to schedule service if you notice loose, pinched, or damaged cables.
23. Contact LUCI for any accessories or cables. Damaged, pinched, frayed, or loose cables should be immediately addressed by a LUCI authorized technician. Frayed or damaged cables should be replaced to ensure proper function of LUCI. Do NOT attempt to replace or fix damaged cables.
24. Damaged, bent, or cracked plastic housings or metal brackets should be immediately replaced to ensure proper function of LUCI. Please contact the LUCI Customer Experience Team immediately to schedule service if you notice damaged, bent, or cracked plastic housings or metal brackets.
25. Do not modify LUCI without the authorization of the manufacturer. Modifying your LUCI equipment will void your warranty and could create unsafe operation of LUCI.
26. LUCI should only be installed by an authorized technician and should not be transferred from one wheelchair to another. The service life for LUCI is equivalent to the service life of the wheelchair.
27. LUCI should be properly disposed of and recycled according to your local disposal regulations for electronic devices. Please contact your LUCI Customer Experience Team if you have any questions about proper disposal and recycling of LUCI at the end of its service life.
28. Please refer to your wheelchair manufacturer user guide for instructions on where your wheelchair is designed to operate. LUCI is designed to detect solid surfaces and may not be able to prevent your wheelchair from getting stuck or detecting all potential unsafe situations if operating in rain, snow, mud, puddles, sand, or other non-solid surfaces your wheelchair manufacturer instructs you to avoid. Please avoid using LUCI in these conditions as it may create unsafe operation of LUCI.
29. LUCI Driver Assist features are designed to operate under the assumption that the driver is alert and monitoring the motion of the wheelchair.
30. As there is a limit to the degree of accuracy and control performance that RampAssist can provide, do not overly rely on this system. The driver is always responsible for paying attention to the wheelchair's motion and surroundings. Let off the joystick if you experience any unexpected behavior.
31. RampAssist assumes properly installed TAGs on safe, structurally sound ramps.
32. RampAssist relies on computer vision to operate. Therefore, lighting conditions, glare, and reflections may limit functionality. Certain ramps (particularly very shiny metal ramps) may not work unless dulled with grip tape or paint. Use of headlights in dark environments will help RampAssist see TAGs more clearly.
33. Reposition or replace TAGs if they are no longer properly positioned, they show a high degree of wear, or if LUCI is starting to have a hard time recognizing them.

TECHNICAL SPECIFICATIONS

LUCI uses multiple types of sensors and transceivers to function. This section provides background information on the technology of LUCI.

OBSTACLE DETECTION

LUCI uses multiple types of sensors to identify and cross-check potential obstacles. The data from these sources is fused and analyzed to ensure the safety of your surroundings. LUCI obstacle detection has the following capabilities.

MINIMUM DETECTION RANGE	Objects closer than 3 cm (1.2 in) to the wheelchair may not be registered accurately	Measured from the edge of the wheelchair
MAXIMUM DETECTION RANGE	Forward: up to 4.5 m (14.8 ft) Backward: up to 1.2 m (3.9 ft) Sides: up to 1.3 m (4.2 ft)	Measured from the edge of the wheelchair
MINIMUM OBJECT DETECTION	Hard objects: 3 cm (1.2 in) Soft objects: 6 cm (2.4 in)	Measured as the cross section of the object facing the wheelchair
LIMITATIONS	Fast moving objects traveling directly at you and objects traveling across your path may not be detected in time to be avoided. Objects smaller than the above minimums, such as cables, may not be detected by LUCI.	

GROUND FEATURE DETECTION

LUCI manages the stability of your wheelchair by monitoring ground features, including the slope of the ground and ramps as well as drop-offs such as curbs and steps.

MINIMUM DETECTION RANGE	Objects closer than 3 cm (1.2 in) to the wheelchair may not be registered accurately	Measured from the edge of the wheelchair
MAXIMUM DETECTION RANGE	Forward: up to 4.5 m (14.8 ft) Backward: up to 1.2 m (3.9 ft) Sides: up to 1.3 m (4.2 ft)	Measured from the edge of the wheelchair
STEP DETECTION	LUCI will detect steps with a height greater than your wheelchair's published step threshold	See your wheelchair user manual for the published step threshold
SLOPE DETECTION	LUCI will detect slopes with an angle greater than your wheelchair's published slope threshold	See your wheelchair user manual for the published slope threshold
LIMITATIONS	Conditions that may challenge the sensors are sudden changes in light level and extremely rough terrain. Mud, snow, water, sand and other soft surfaces may be incorrectly detected as rigid and/or safe surfaces.	

RECOMMENDED MINIMUM R-NET SETTINGS

LUCI is tuned to work best with factory default R-NET settings. Increasing top speeds and accelerations or decreasing deceleration in R-NET from default settings may prevent LUCI from stopping the wheelchair effectively. If adjusting R-NET settings is needed, especially for low-speed drivers, we recommend maintaining values above the minimum R-NET settings shown in the table below. R-NET settings should only be adjusted by qualified personnel.

PARAMETER (PC PROGRAMMER)	(OBP)	Forward	Reverse	Turning
MAXIMUM ACCELERATION	Accel ▲	20	22	17
MINIMUM ACCELERATION	Accel ▼	8	9	5
MAXIMUM DECELERATION	Decel ▲	15	9	22
MINIMUM DECELERATION	Decel ▼	15	9	9
MAXIMUM SPEED	Speed ▲	60	18	18
MINIMUM SPEED	Speed ▼	15	10	7
POWER	Power	100	--	--
TORQUE	Torque	100	--	--

EMISSIONS AND IMMUNITY STANDARDS COMPLIANCE

TEST STANDARD	TEST LEVEL	POWER INPUT
Radiated Emission CISPR11 ed5.0 (with A1:2010)	Class B	Configuration: 24 VDC
Electro-Static Discharge Immunity Test IEC 61000-4-2 ed2.0 (2008-12)	± 8 kV contact ± 2 kV, ± 4 kV, ± 8 kV, ± 15 kV air	Configuration: 24 VDC
Radiated, Radio-Frequency, Electromagnetic Immunity IEC 61000-4-3 ed3.0 (with A1:2007+A2:2010)	10 V/m (Home Health Care) 80 MHz – 2.7 GHz 80% AM at 1 KHz	Configuration: 24 VDC
Conducted, Radio-Frequency, Electromagnetic Immunity Test IEC 61000-4-6 ed2.0 (with A1:2004+A2:2006)	DC Mains: (Home Health care) 3 V, 0.15 MHz – 80 MHz 6 V in ISM and Amateur band between 15 MHz and 80 MHz 80% AM at 1 KHz [see table 6 of IEC 60601-1-2]	Configuration: 24 VDC
Power Frequency Magnetic Field Immunity Test IEC 61000- 4-8 ed2.0 (2009-09)	30 A/m, 50 Hz or 60 Hz	Configuration: 24 VDC
Proximity fields from RF wireless communications equipment Clause 8.10. The frequencies and services listed in Table 9 are representative examples that are based on RF communications equipment in use at the time of publication of this collateral standard. The test specification does not attempt to cover every frequency and service used in every country.	Per Table 9	Configuration: 24 VDC

POWER

LUCI does not have its own power source. Instead, LUCI uses your wheelchair battery for power. This means you do not have a separate device to charge; charging your wheelchair per its manufacturer's specifications will suffice. LUCI has been designed so that the power usage to run LUCI is minimal and should not significantly affect the battery life of your wheelchair. If your wheelchair will not be used for one week or more, flip the breaker off, or disconnect the battery to avoid draining the battery.

POWER
24 VDC ± 4 VDC, 1.5 ADC MAX

SENSOR TRANSMISSION

LUCI produces acoustic emissions in the 40-60 kHz frequency range.

LUCI produces RF emissions in the 77-81 GHz frequency range. The maximum effective radiated power is less than 90 mW.

LUCI is classified as a Class 1 Laser Product under the EN/IEC 60825-1, Edition 3 (2014) internationally and IEC60825-1, Edition 2 (2007) in the US.

LUCI complies with US FDA performance standards under 21 CFR 1040.10 for laser products, except for deviations pursuant to Laser Notice No. 50 dated June 24, 2007.

COMMUNICATION

In addition to the sensors listed above, LUCI also uses cellular, Bluetooth, Wi-Fi and GPS.

CELLULAR	BLUETOOTH	WI - FI	GPS
4G LTE CAT M1	Bluetooth 5.0	802.11a/b/g/n Wi-Fi	GNSS Receiver

CELLULAR CONNECTIVITY

When not connected to a known Wi-Fi network that you set up, LUCI will automatically connect to the cellular network, where service is available. In this situation, the green cellular connection indicator light will illuminate.

The cellular radio operates in transmit and receive in the following bands with a max EIRP of 27.9dBm.

LTE BAND	TRANSMIT BAND MIN (MHz)	TRANSMIT BAND MAX (MHz)	RECEIVE BAND MIN (MHz)	RECEIVE BAND MAX (MHz)
B2	1850	1910	1930	1990
B4	1710	1755	2110	2155
B12	699	716	729	746



BLUETOOTH AND WI - FI

The Bluetooth and Wi-Fi communications operate in transmit and receive mode in the following bands.

BAND	FREQUENCY RANGE MIN (MHz)	FREQUENCY RANGE MAX (MHz)	MAX EIRP (DBM)
2.4 GHz Wi-Fi	2400	2483	18.1
5 GHz Wi-Fi	4900	5925	17.5
Bluetooth	2400	2435	14.1

GPS

LUCI includes global positioning hardware, which allows it to include your current location in notifications. You can choose whether or not to share your location with others in text alerts via the LUCI web portal at myLUCI.com or in the MyLUCI® app. The GNSS positioning system operates in receive mode only in the following bands.

BAND	RECEIVE BAND MIN (MHz)	RECEIVE BAND MAX (MHz)
GPS	1575	N/A
GLONASS	1597	1606
BeiDou	1559	1591

RADAR

The radar sensors in LUCI operate in transmit and receive mode in the following bands.

BAND	FREQUENCY RANGE MIN (MHz)	FREQUENCY RANGE MAX (MHz)	MAX EIRP (DBM)
mmWave Radar	77000	81000	15.7

FCC CERTIFIED TRANSMITTER MODULES

LUCI contains the following FCC Certified transmitter modules:

FCC ID: N7NHL78M

This transmitter module is authorized only for use in device where the antenna may be installed such that 20 cm may be maintained between the antenna and users. This transmitter must not be co-located or operating in conjunction with any other antenna or transmitter. Questions about this module should be directed to Sierra Wireless at 1-877-687-7795.

FCC ID: T7B-9026

This equipment has been tested and found to comply with the limits for a Class B digital device, pursuant to Part 15 of the FCC Rules. These limits are designed to provide reasonable protection against harmful interference in a residential installation. This equipment generates uses and can radiate radio frequency energy and, if not installed and used in accordance with the instructions, may cause harmful interference to radio communications. Questions about this module should be directed to Panasonic at 1-800-344-2112.

FCC ID: 2ASQOP003110

This equipment has been tested and found to comply with the limits for a mobile device with respect to RF exposure, pursuant to Part 95M of the FCC Rules. The antenna(s) used for this transmitter must be installed to provide a separation distance of at least 20 cm from all persons and must not be co-located or operating in conjunction with any other antenna or transmitter, except as in accordance with FCC multi-transmitter product guidelines. Questions about this module should be directed to Patroness LLC at 615-813-5824.

NOTES



REIMAGINING MOBILITY[®]

101 Creekside Crossing, Ste 1700, #244
Brentwood, TN 37027

info@luci.com
luci.com

CUSTOMER EXPERIENCE TEAM

615-813-LUCI
lucihelps@luci.com

Serial No.



Copyright © 2023 LUCI Mobility, Inc. All Rights Reserved.
613-00003 Revision B
For Lucicore[®] 2.0 or newer